

LR Series

LED Highbay for Food Industry 100W, 150W and 200W







- Large size die- cast heatsink diameter up to 135 mm, low glare UGR<16, ultra-smooth light output.
- Aesthetically smooth design with hidden screws, excellent for food process application.
- Excellent heat dissipation for MAX 60 degree ambient working temperature.
- Smart-ready with AUX output and center-in stalled sensor or control modules available.
- Built in surge protection 6KV

More Informations
Visit our website >>







Specifications

Model	Wattage	Luminous Flux	Input Voltage	Power Factor	Temperature Color	CRI	Working Temperature	Life Span	Warranty
KC-HB10LR14-A	100	14500 lm	180 - 277 VAC	0.95	3000K/6500K	80 Ra	- 20 to 60°C	50000 Hrs	2 Years
KC-HB15LR14-A	150	22500 lm	180 - 277 VAC	0.95	3000K/6500K	80 Ra	- 20 to 60°C	50000 Hrs	2 Years
KC-HB20LR14-A	200	29000 lm	180 - 277 VAC	0.95	3000K/6500K	80 Ra	- 20 to 60 °C	50000 Hrs	2 Years

Structure Diagram

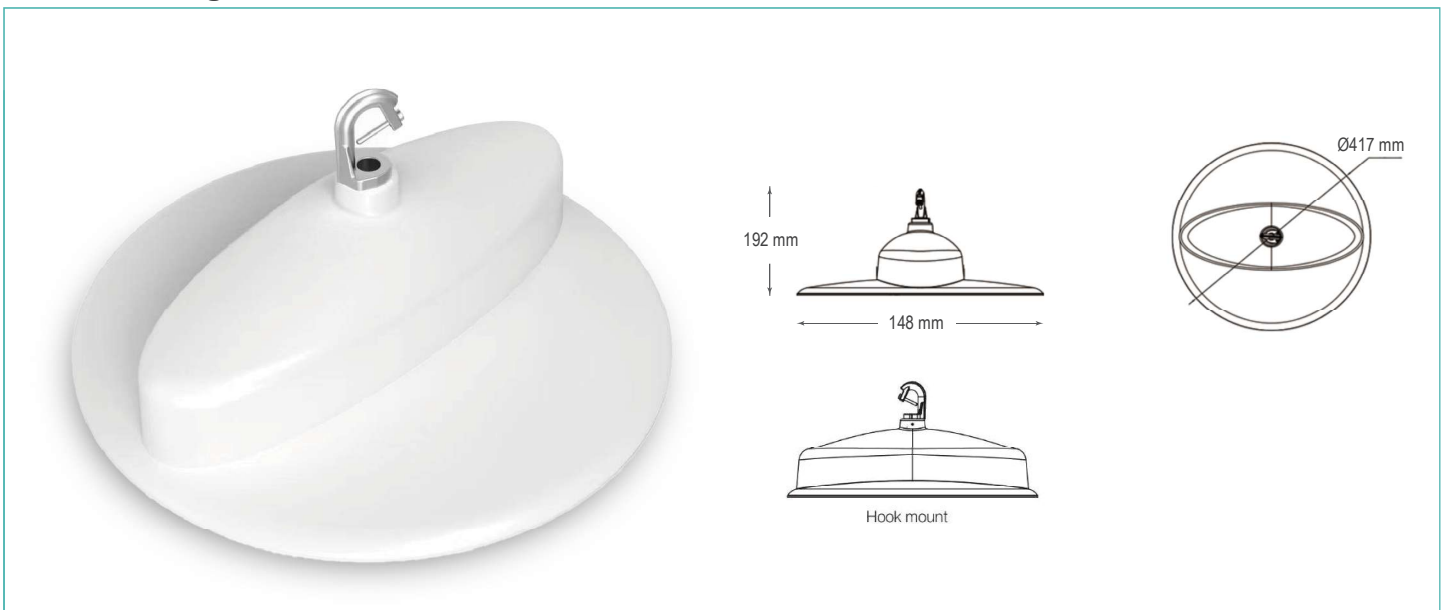

Light Distribution

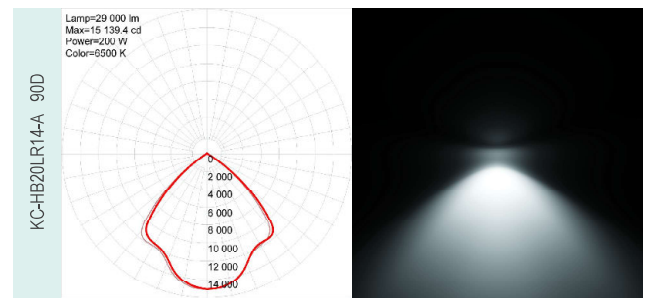
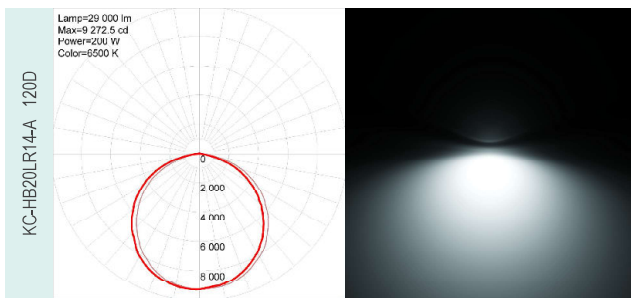
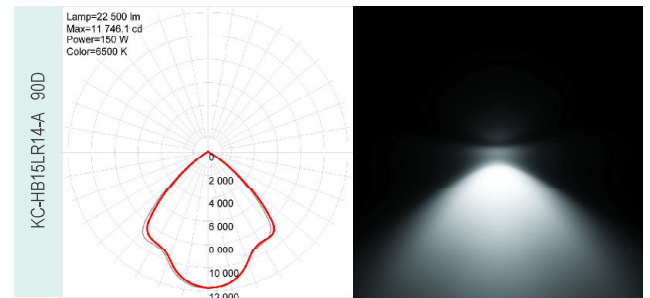
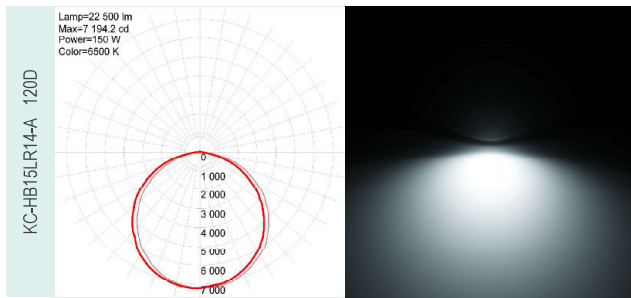
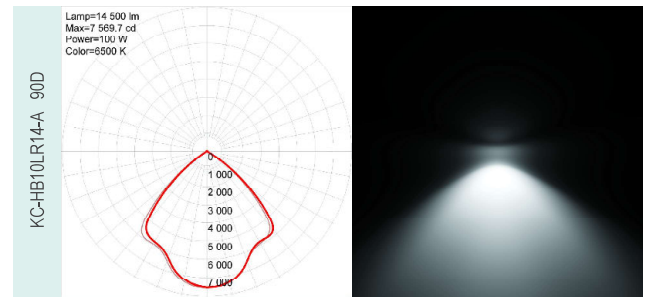
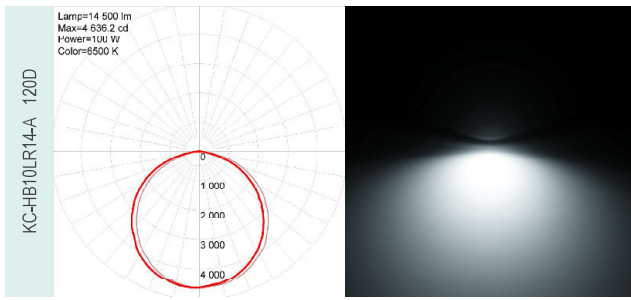

Accessories



Detection Sensor



External emergency kit,
AC120-347V 20W 180mins
from Billa



PC Dot lens available for
60D, 90D and 120D