

Product Description

- Simple structure, good interchangeability, and low price.
- The stem seal is not easily deformed to avoid the normal stem leakage, and the overall support is good, stable and firm.
- With less seat rubber, there is less potential for expansion and it is easier to control the torque within the proper range.
- The use of two-piece valve stems with no pin connection, the structure is simple and compact, and maintenance and disassembly are very convenient.
- The butterfly board has the function of automatic centering, and the butterfly board and valve seat are closely matched.

The phenolic back valve seat has the characteristics of not falling off, tensile resistance, leakage prevention and easy replacement.

- Surface: Polyester, RAL9006, 100μ
- Face-to-face: EN558-1
- Counter flange: DN40-DN300, PN10/16/ANSI150
- BS10 TABLE D/E, JIS 10K, 16K
- DN350 -DN600 PN10 or ANSI150 BS10 TABLE D/E



Main Specification

Nominal Size	Operated Type	Pressure	Temperature	Seal Material	Disc Material	Body Material	Medium	Application	Connection Standard
DN50 ↓ 350	Pneumatic Actuator	PN2	-15-85°C	PTFE	WCB	Ductile Iron	Strong Acid Strong Alkali Fodder	Water Gas Fodder	PN10/PN16
	Electric Actuator	PN1.0	-15-150°C	EPDM	SS304				ANSI150
	Manual Hand Lever	PN1.6		SS316	DIN16				
	Worm Gear		Polishing Plate	JIS10K/16K					

Visit our website to know more details: www.flowxcontrol.com

U TYPE FLANGED BUTTERFLY VALVE



Manual Handle Lever Operated

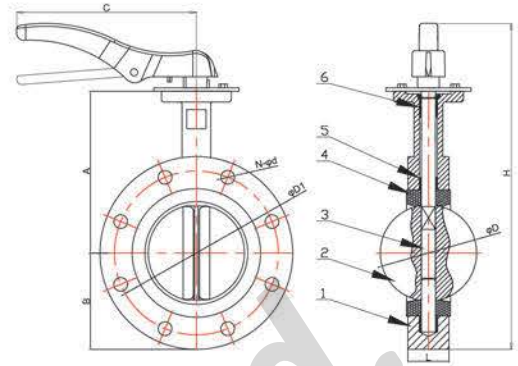

■ Dimensions

unit: mm

Size		CLASS150		JIS 10K		PN10		PN16		A	B	ΦD	L	H	C	WT (kg)
DN	NPS	D1	N-Φd1	D1	N-Φd1	D1	N-Φd1	D1	N-Φd1							
50	2"	120.6	4-Φ19.1	120	4-Φ19	125	4-Φ19	125	4-Φ19	161	83	52.9	42	312	213	-
65	2½"	139.7	4-Φ19.1	140	4-Φ19	145	4-Φ19	145	4-Φ19	175	93	64.5	45	336	213	-
80	3"	152.4	4-Φ19.1	150	8-Φ19	160	8-Φ19	160	8-Φ19	181	95	78.8	46	344	213	-
100	4"	190.5	8-Φ19.1	175	8-Φ19	180	8-Φ19	180	8-Φ19	200	114	104	52	403	277	-
125	5"	215.9	8-Φ22.4	210	8-Φ23	210	8-Φ19	210	8-Φ19	213	127	123.3	55	429	277	-
150	6"	241.3	8-Φ22.4	240	8-Φ23	240	8-Φ23	240	8-Φ23	226	139	155.1	56	454	277	-
200	8"	298.5	8-Φ22.4	290	12-Φ23	295	8-Φ23	295	12-Φ23	260	175	202.5	61	-	-	-
250	10"	361.9	12-Φ22.4	355	12-Φ25	350	12-Φ23	355	12-Φ28	292	203	250.5	66	-	-	-
300	12"	431.8	12-Φ22.4	400	16-Φ25	400	12-Φ23	410	12-Φ28	337	242	301.5	77	-	-	-
350	14"	476	12-Φ28.5	445	16-Φ25	460	16-Φ23	470	16-Φ28	368	267	333.3	77	-	-	-

Worm Gear Operated

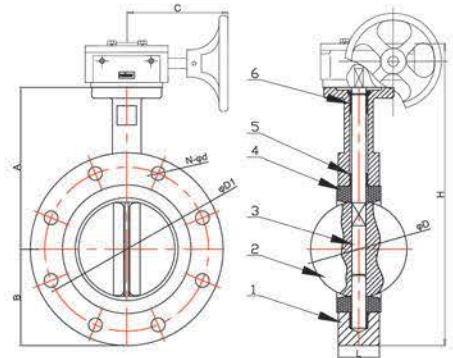

■ Dimensions

unit: mm

Size		CLASS150		JIS 10K		PN10		PN16		A	B	ΦD	L	H	C	WT (kg)
DN	NPS	D1	N-Φd1	D1	N-Φd1	D1	N-Φd1	D1	N-Φd1							
50	2"	120.6	4-Φ19.1	120	4-Φ19	125	4-Φ19	125	4-Φ19	161	83	52.9	42	292	99	-
65	2½"	139.7	4-Φ19.1	140	4-Φ19	145	4-Φ19	145	4-Φ19	175	93	64.5	45	316	99	-
80	3"	152.4	4-Φ19.1	150	8-Φ19	160	8-Φ19	160	8-Φ19	181	95	78.8	46	324	99	-
100	4"	190.5	8-Φ19.1	175	8-Φ19	180	8-Φ19	180	8-Φ19	200	114	104	52	362	99	-
125	5"	215.9	8-Φ22.4	210	8-Φ23	210	8-Φ19	210	8-Φ19	213	127	123.3	55	394	115	-
150	6"	241.3	8-Φ22.4	240	8-Φ23	240	8-Φ23	240	8-Φ23	226	139	155.1	56	419	115	-
200	8"	298.5	8-Φ22.4	290	12-Φ23	295	8-Φ23	295	12-Φ23	260	175	202.5	61	506	220	-
250	10"	361.9	12-Φ22.4	355	12-Φ25	350	12-Φ23	355	12-Φ28	292	203	250.5	66	566	220	-
300	12"	431.8	12-Φ22.4	400	16-Φ25	400	12-Φ23	410	12-Φ28	337	242	301.5	77	650	220	-
350	14"	476	12-Φ28.5	445	16-Φ25	460	16-Φ23	470	16-Φ28	368	267	333.3	77	715	323	-

Pneumatic Actuator Operated

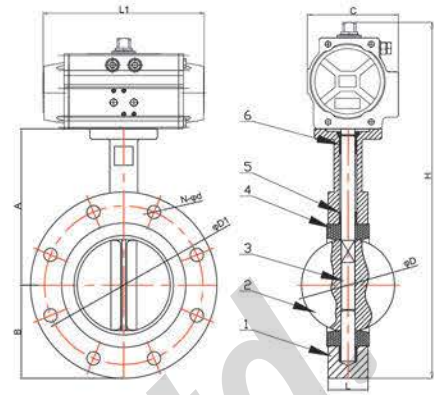

Dimensions

unit: mm

Size		CLASS150		JIS 10K		PN10		PN16		A	B	ΦD	L	H	L1	C	WT (kg)
DN	NPS	D1	N-Φd1	D1	N-Φd1	D1	N-Φd1	D1	N-Φd1								
50	2"	120.6	4-Φ19.1	120	4-Φ19	125	4-Φ19	125	4-Φ19	161	83	52.9	42	333.5	139.5	71	-
65	2½"	139.7	4-Φ19.1	140	4-Φ19	145	4-Φ19	145	4-Φ19	175	93	64.5	45	368.5	162	80.5	-
80	3"	152.4	4-Φ19.1	150	8-Φ19	160	8-Φ19	160	8-Φ19	181	95	78.8	46	376.5	162	80.5	-
100	4"	190.5	8-Φ19.1	175	8-Φ19	180	8-Φ19	180	8-Φ19	200	114	104	52	431	207	95	-
125	5"	215.9	8-Φ22.4	210	8-Φ23	210	8-Φ19	210	8-Φ19	213	127	123.3	55	468.5	237.5	106	-
150	6"	241.3	8-Φ22.4	240	8-Φ23	240	8-Φ23	240	8-Φ23	226	139	155.1	56	542.5	271.5	123	-
200	8"	298.5	8-Φ22.4	290	12-Φ23	295	8-Φ23	295	12-Φ23	260	175	202.5	61	606.5	328	137	-
250	10"	361.9	12-Φ22.4	355	12-Φ25	350	12-Φ23	355	12-Φ28	292	203	250.5	66	678.5	366	148	-
300	12"	431.8	12-Φ22.4	400	16-Φ25	400	12-Φ23	410	12-Φ28	337	242	301.5	77	785	428	164	-
350	14"	476	12-Φ28.5	445	16-Φ25	460	16-Φ23	470	16-Φ28	368	267	333.3	77	857	430	186.5	-

Electric Actuator Operated

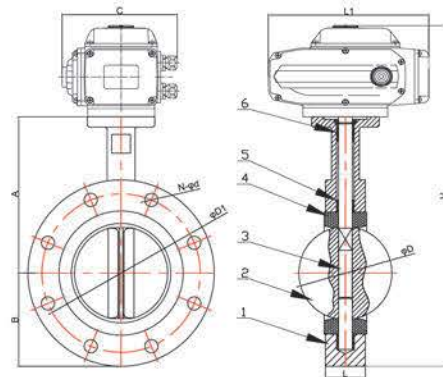

Dimensions

unit: mm

Size		CLASS150		JIS 10K		PN10		PN16		A	B	ΦD	L	H	L1	C	WT (kg)
DN	NPS	D1	N-Φd1	D1	N-Φd1	D1	N-Φd1	D1	N-Φd1								
50	2"	120.6	4-Φ19.1	120	4-Φ19	125	4-Φ19	125	4-Φ19	161	83	52.9	42	381.5	165	140.5	-
65	2½"	139.7	4-Φ19.1	140	4-Φ19	145	4-Φ19	145	4-Φ19	175	93	64.5	45	405.5	165	140.5	-
80	3"	152.4	4-Φ19.1	150	8-Φ19	160	8-Φ19	160	8-Φ19	181	95	78.8	46	413.5	165	140.5	-
100	4"	190.5	8-Φ19.1	175	8-Φ19	180	8-Φ19	180	8-Φ19	200	114	104	52	482.5	211.5	154	-
125	5"	215.9	8-Φ22.4	210	8-Φ23	210	8-Φ19	210	8-Φ19	213	127	123.3	55	508.5	211.5	154	-
150	6"	241.3	8-Φ22.4	240	8-Φ23	240	8-Φ23	240	8-Φ23	226	139	155.1	56	568	259	186	-
200	8"	298.5	8-Φ22.4	290	12-Φ23	295	8-Φ23	295	12-Φ23	260	175	202.5	61	638	259	186	-
250	10"	361.9	12-Φ22.4	355	12-Φ25	350	12-Φ23	355	12-Φ28	292	203	250.5	66	698	259	186	-
300	12"	431.8	12-Φ22.4	400	16-Φ25	400	12-Φ23	410	12-Φ28	337	242	301.5	77	808.5	283.5	193	-
350	14"	476	12-Φ28.5	445	16-Φ25	460	16-Φ23	470	16-Φ28	368	267	333.3	77	864.5	283.5	193	-

U TYPE FLANGED BUTTERFLY VALVE



Technical Material List

APPLICABLE STANDARDS & TECHNICAL NOTES:							
DESIGN CODE		API609		END STANDARD		ANSI 150#/JIS 10K	
INSPECTION&TEST		API598		FACE TO FACE		API609	
NO.	PARTS NAME	MATERIAL	QTY	NO.	PARTS NAEM	MATERIAL	QTY
1	BODY	DI/WCB/CF8/CF8M	1	4	SEAT	NBR/EPDM/PTFE/VITON	1
2	DISC	WCB/DI+NYLON/CF8/CF8M	1	5	BUSHING	PTFE	4
3	SHAFT	SS410	1	6	O-RING	NBR	1
TEST PRESSURE							
		SHELL			SEAL		
HYDROSTATIC		24/15 kg/cm ²			17.6/11 kg/cm ²		
AIR		—			—		
TITLE: U TYPE FLANGED BUTTERFLY VALVE							
SIZE		DN50-DN350		DWG NO.		FT0114000003-1.1	

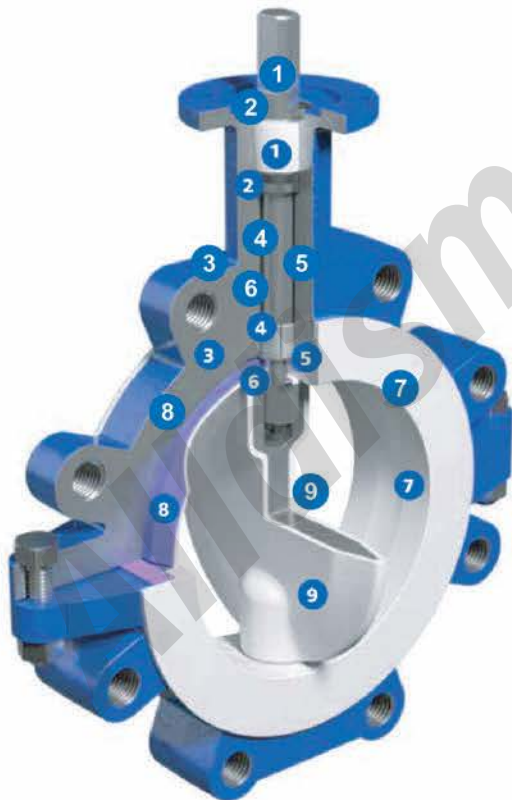

1 – UPPER STEM BUSHING: An upper stem bushing, retained by a stainless steel ring, is provided to absorb actuator side thrusts and is acetal as standard or PTFE as an option.

2 – UPPER STEM SEAL: Keeps environmental contaminants from entering the stem bore.

3 – BODY: Bodies are two piece wafer or lug style and are epoxy coated. All bodies meet full ASME Class 150 OR DIN 3840 flange drilling requirements (24" body is double flanged).

4 – BEARINGS: PTFE impregnated steel bearings provided for the precision alignment of the upper and lower stem.

5 – BLOWOUT PROOF STEM: A shoulder is machined into the upper stem. The stem and the disc are pressed together during assembly creating a positive stem to disc connection.

6 – PRIMARY SEAL: The primary seal is achieved by an interference fit between the extra wide disc hubs and contoured seat.

7 – SEAT DESIGN: The unique seat geometry lowers seating and unseating torque while reducing wear on the contacting parts.

8 – SEAT ENERGIZER: A resilient seat energizer extends completely around the seat, including the disc hub providing uniform force sufficient for bubble tight shutoff.

9 – DISC: The encapsulated disc has 1/8" (3 mm) minimum thickness of virgin PTFE or PFA lined over stainless steel.