

Features

- Small and lightweight, easy to disassemble and repair, and can be installed in any position.
- The structure is simple and compact, the operating torque is small, and the rotation of 90° turns on quickly.
- The flow characteristics of the linear trend, good regulation performance.
- The connection between the butterfly plate and the valve stem adopts a non-pin structure to overcome possible internal leakage points.
- The spherical shape of the outer circle of the butterfly plate improves the sealing performance and prolongs the service life of the valve. The zero leakage is still maintained when the pressure is switched on and off more than 50,000 times.
- The seal can be replaced, and the seal is reliable to achieve two-way seal.
- The butterfly board can be sprayed with layers according to user requirements, such as nylon or polytetrafluoroethylene.
- Flange butterfly valve is suitable for temperature $\leq 120\text{ }^{\circ}\text{C}$ or $\leq 150\text{ }^{\circ}\text{C}$, nominal pressure $\leq 1.6\text{MPa}$ water supply and drainage, sewage, food, heating, gas, shipbuilding, hydropower, metallurgy, energy systems and textile and other industries, especially for two-way sealing and Easy to corrode valve body, adjust flow and shutoff medium.



Main Specification

Nominal Size	Operated Type	Work Pressure	Work Temperature	Seal Material	Disc Material	Body Material	Medium	Application	Connection Standard
DN25	Pneumatic Actuator	PN6	-15-85°C	EPDM	SS304/SS316	Ductile Iron	Water	Water Treatment	PN10/PN16
	Electric Actuator	PN10	-25-150°C	PTFE	Aluminum Bronze	SS304/SS316	Oil	Municipal Engineer	ANSI150
	Manual Hand Lever	PN16	-15-85°C	NBR	Nylon	WCB	Gas	Pharmacy	DIN16
1200	Worm Gear		-25-200°C	VITON	Ductile Iron	Aluminium Alloy	Powder	Auto Industry	JIS10K/16K
					2205	2205	FGDD		
					2507	2507			
					1.4529	1.4529			

Visit our website to know more details: www.flowxcontrol.com

Manual Handle Lever Operated

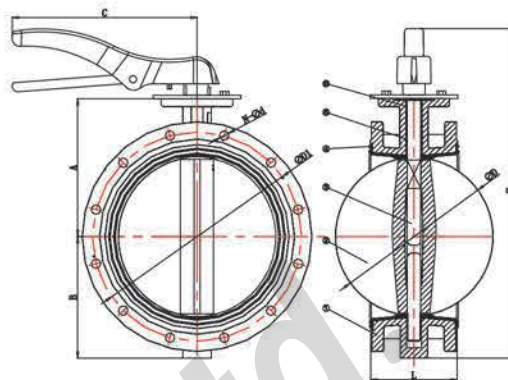

Dimensions

unit: mm

Size		CLASS150		JIS 10K		PN10		PN16		A	B	L	ΦD	H	C	WT (kg)
DN	NPS	D1	N-Φd1	D1	N-Φd1	D1	N-Φd1	D1	N-Φd1							
50	2"	120.6	4-Φ19.1	120	4-Φ19	125	4-Φ19	125	4-Φ19	118	75	108	52.9	261	213	6.8
65	2½"	139.7	4-Φ19.1	140	4-Φ19	145	4-Φ19	145	4-Φ19	130	93	112	64.5	291	213	9.6
80	3"	152.4	4-Φ19.1	150	8-Φ19	160	8-Φ19	160	8-Φ19	145	100	114	78.8	313	213	10
100	4"	190.5	8-Φ19.1	175	8-Φ19	180	8-Φ19	180	8-Φ19	155	114	127	104	342	277	12.2
125	5"	215.9	8-Φ22.5	210	8-Φ23	210	8-Φ19	210	8-Φ23	170	125	140	123.3	368	277	17.1
150	6"	241.3	8-Φ22.5	240	8-Φ23	240	8-Φ23	240	8-Φ23	190	143	140	155.1	406	277	29.4
200	8"	298.5	8-Φ22.5	290	12-Φ23	295	8-Φ23	295	12-Φ23	205	170	152	202.5	448	277	27.9

Worm Gear Operated

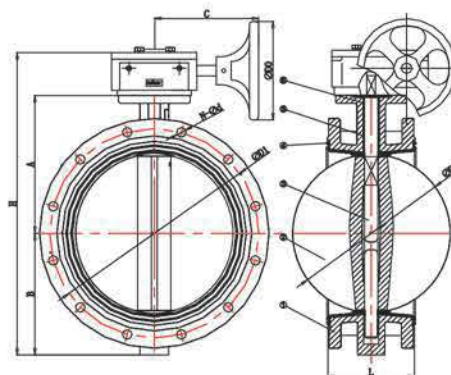

Dimensions

unit: mm

Size		CLASS150		JIS 10K		PN10		PN16		A	B	L	ΦD	H	C	ΦD0	WT (kg)
DN	NPS	D1	N-Φd1	D1	N-Φd1	D1	N-Φd1	D1	N-Φd1								
50	2"	120.6	4-Φ19.1	120	4-Φ19	125	4-Φ19	125	4-Φ19	118	75	108	52.9	241	99	120	7.2
65	2½"	139.7	4-Φ19.1	140	4-Φ19	145	4-Φ19	145	4-Φ19	130	93	112	64.5	271	99	120	10
80	3"	152.4	4-Φ19.1	150	8-Φ19	160	8-Φ19	160	8-Φ19	145	100	114	78.8	293	99	120	10.4
100	4"	190.5	8-Φ19.1	175	8-Φ19	180	8-Φ19	180	8-Φ19	155	114	127	104	317	99	120	12.6
125	5"	215.9	8-Φ22.5	210	8-Φ23	210	8-Φ23	210	8-Φ23	170	125	140	123.3	349	115	200	18.3
150	6"	241.3	8-Φ22.5	240	8-Φ23	240	8-Φ23	240	8-Φ23	190	143	140	155.1	387	115	200	20.6
200	8"	298.5	8-Φ22.5	290	12-Φ23	295	8-Φ23	295	12-Φ23	205	170	152	202.5	446	220	300	32.6
250	10"	361.9	12-Φ25.5	355	12-Φ25	350	12-Φ23	355	12-Φ28	235	198	165	250.5	504	220	300	46.1
300	12"	431.8	12-Φ25.5	400	16-Φ25	400	12-Φ23	410	12-Φ28	280	223	178	301.5	574	220	300	61.4

Pneumatic Actuator Operated

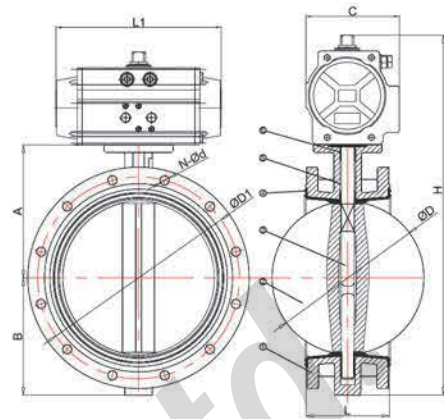

Dimensions

unit: mm

Size		CLASS150		JIS 10K		PN10		PN16		A	B	L	ΦD	H	L1	C	WT (kg)
DN	NPS	D1	N-Φd1	D1	N-Φd1	D1	N-Φd1	D1	N-Φd1								
50	2"	120.6	4-Φ19.1	120	4-Φ19	125	4-Φ19	125	4-Φ19	118	75	108	52.9	282.5	139.5	71	6.9
65	2½"	139.7	4-Φ19.1	140	4-Φ19	145	4-Φ19	145	4-Φ19	130	93	112	64.5	323.5	162	80.5	11.2
80	3"	152.4	4-Φ19.1	150	8-Φ19	160	8-Φ19	160	8-Φ19	145	100	114	78.8	345.5	162	80.5	11.6
100	4"	190.5	8-Φ19.1	175	8-Φ19	180	8-Φ19	180	8-Φ19	155	114	127	104	386	207	95	14.8
125	5"	215.9	8-Φ22.5	210	8-Φ23	210	8-Φ23	210	8-Φ19	170	125	140	123.3	423.5	237.5	106	20.6
150	6"	241.3	8-Φ22.5	240	8-Φ23	240	8-Φ23	240	8-Φ23	190	143	140	155.1	474.5	271.5	123	24.5
200	8"	298.5	8-Φ22.5	290	12-Φ23	295	8-Φ23	295	12-Φ23	205	170	152	202.5	546.5	328	137	36
250	10"	361.9	12-Φ25.5	355	12-Φ25	350	12-Φ23	355	12-Φ28	235	198	165	250.5	616.5	366	148	51.3
300	12"	540.0	12-Φ25.5	400	16-Φ25	400	12-Φ23	410	12-Φ28	280	223	178	301.5	709	428	164	71.8
350	14"	578.0	12-Φ28.5	455	16-Φ25	460	16-Φ23	470	16-Φ28	328	250	190	333.3	800	430	186.5	102

Electric Actuator Operated

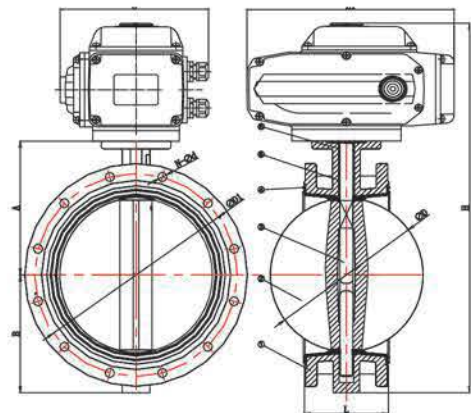

Dimensions

unit: mm

Size		CLASS150		JIS 10K		PN10		PN16		A	B	L	ΦD	H	L1	C	WT (kg)
DN	NPS	D1	N-Φd1	D1	N-Φd1	D1	N-Φd1	D1	N-Φd1								
50	2"	120.6	4-Φ19.1	120	4-Φ19	125	4-Φ19	125	4-Φ19	118	75	108	52.9	330.5	165	140.5	8.3
65	2½"	139.7	4-Φ19.1	140	4-Φ19	145	4-Φ19	145	4-Φ19	130	93	112	64.5	360.5	165	140.5	11.1
80	3"	152.4	4-Φ19.1	150	8-Φ19	160	8-Φ19	160	8-Φ19	145	100	114	78.8	382.5	165	140.5	11.5
100	4"	190.5	8-Φ19.1	175	8-Φ19	180	8-Φ19	180	8-Φ19	155	114	127	104	437.5	211.5	154	15.5
125	5"	215.9	8-Φ22.5	210	8-Φ23	210	8-Φ23	210	8-Φ19	170	125	140	123.3	463.5	211.5	154	20.4
150	6"	241.3	8-Φ22.5	240	8-Φ23	240	8-Φ23	240	8-Φ23	190	143	140	155.1	536	259	186	25.7
200	8"	298.5	8-Φ22.5	290	12-Φ23	295	8-Φ23	295	12-Φ23	205	170	152	202.5	578	259	186	34.5
250	10"	361.8	12-Φ25.5	355	12-Φ25	350	12-Φ23	355	12-Φ28	235	198	165	250.5	636	259	186	48.5
300	12"	431.8	12-Φ25.5	400	16-Φ25	400	12-Φ23	410	12-Φ28	280	223	178	301.5	732.5	283.5	193	67.3
350	14"	476.5	12-Φ28.5	445	16-Φ25	460	16-Φ23	470	16-Φ28	328	250	190	333.3	807.5	283.5	193	94.5

Technical Material List

APPLICABLE STANDARDS & TECHNICAL NOTES:							
DESIGN CODE	API609			END STANDARD	ANSI 150#/JIS 10K		
INSPECTION&TEST	API598			FACE TO FACE	API609		
NO.	PARTS NAME	MATERIAL	QTY	NO.	PARTS NAME	MATERIAL	QTY
1	BODY	DI/WCB/CF8/CF8M	1	4	SEAT	NBR/EPDM/VITON	1
2	DISC	WCB/DI+NYLON/CF8/CF8M	1	5	BUSHING	PTFE	4
3	SHAFT	SS410	1	6	O-RING	NBR	1
TEST PRESSURE							
		SHELL		SEAL			
HYDROSTATIC		24/15 kg/cm ²		17.6/11 kg/cm ²			
AIR		—		—			
TITLE: PNEUMATIC FLANGE BUTTERFLY VALVE							
SIZE	DN50-DN250			DWG NO.	FT0114000002-1		



1 – STEM: Precision square and double "D" disc to stem connection drives the disc without the need for screws or pins. The close tolerance, square and double "D" connection that drives the valve disc is an exclusive feature of the Flowx valve. Disassembly of the Flowx stem is just a matter of pulling the stem out of the disc.

2 – STEM RETAINING ASSEMBLY: The stem is retained in the body by means of a unique stainless steel Spirolox® retaining ring, a thrust washer and two C-rings, manufactured from brass as standard, stainless steel upon request.

3 – STEM BUSHING: Non-corrosive, heavy duty acetal bushing absorbs actuator side thrusts.

4 – STEM SEAL: Double "U" cup seal design is self-adjusting, gives positive sealing in both directions, and prevents external substances from entering the stem bore.

5 – PRIMARY AND SECONDARY SEALS: These seals prevent line media from coming in contact with the stem or body. The primary seal is an interference fit of the molded seat flat with the disc hub. The secondary seal is created because the stem diameter is greater than the diameter of the seat stem hole.

6 – DISC: Casting is spherically machined and hand polished to provide a bubble tight shutoff, minimum torque, and longer seat life. Flowx's resilient Nylon 11 coating comes as standard.

7 – SEAT: Flowx's bonded seat offers lower torque and provides complete isolation of flowing media from the body. The seat also features a molded O-ring which eliminates the use of flange gaskets.