

防混蝶阀+蝶阀
Mixing proof butterfly valve
+ Butterfly valve

0.4



 **Aldismo**®

Alldismo Co.,Ltd.
362/1 Soi Rama Nine 20, Rama 9 Rd.,
Bangkapi, Huai-Khwang District, Bangkok 10310
Thailand

国家高新技术企业 浙江省著名商标
www.cndonjoy.com

 **DONJOY 东正**

东正一直致力于重大技术进步，是您值得信赖的事业伙伴！
Donjoy committing to major technological advances, is your reliable business partner!

0.1	自控调节阀+控制器 Automatic control regulating valve +Control head
0.2	生物制药隔膜阀 Biopharmaceutical diaphragm valve
0.3	高洁净泵 High purity pumps
0.4	防混蝶阀+蝶阀 Mixing proof butterfly valve +Butterfly valve
0.5	球阀 Ball valve
0.6	截止换向阀+防混阀+罐底阀 Divert seat valve+Mixing proof valve +Tank bottom valve
0.7	角座阀+截止阀 Angle seat valve+Globe valve
0.8	止回阀+恒压阀+安全阀+减压阀 Check valve+constant pressure valve+safety valve +air release valve
0.9	清洁技术+取样阀+视镜+照明技术 Clean technology+sample valve+sight glass +lighting technology
0.10	过滤器+人孔 Filter+man hole cover(manway)
0.11	卫生管件 Sanitary fittings ASME BPE DIN11852 B94825 SMS ISO IDF 3A



注意：
目录技术资料仅供设计参考，
设计更新和技术升级恕不另行通知！

不断革新的技术、日新月异的市场发展和客户需求是当今我们面临的巨大挑战。面对这些挑战我们信心十足，因为东正高度专业化的产品和技术创新，是我们未来将以更高、更优的产品来满足不断增长的市场需求。

Technological innovation, rapid development of the market and customer needs are the greatest challenges facing us today. Facing with these challenges we are confident, because of highly professional products and technological innovation, we will meet the growing demand of market and customer with our better and better products.

法律声明：
目录样册版本属东正所有，如有抄袭东正将追究其法律责任和经济赔偿。
东正众多技术设计，都具有专利保护，如有抄袭，东正必将追究法律责任和经济赔偿。

领先源于创新 创新源于专业

东正的专业与品质的邂逅源于创新的精神



现代化工厂已经投产，期待您的光临！
温州空港经济园区生产基地
Wenzhou airport economic zone production base

占地面积29000m²，总投资1.2亿元，新引进ABB工业机器人、日本马扎克5轴加工中心、ABB机器人抛光设备。

东正创立于1993年，注册资金5508万，是一家专注于研发高品质PID过程控制器、阀门定位器、流量控制器，阀门控制单元，高洁净过程控制阀、智能自控阀，高洁净泵、高洁净管材和管道配件。公司高度专业化的产品和技术专注于生物制药、食品饮料、酿酒、精细化工等工业领域。东正众多的创新解决方案，对满足全球，尤其是新兴市场不断增长生物制药和食品饮料行业的需求起到了积极作用。

Covering an area of 29000 m², with total investment after construction is expected to 120 million yuan, introduces new ABB industrial robot, Japan mazar-e-sharif grams of five axis machining center, ABB machine Polishing equipment.

东正制造的产品母材料、加工技术、焊接技术、表面处理等技术指标均已达到国内外先进水平。且符合ASME BPE、EHEDG、FDA、3A等一系列国际标准和规范要求，先后通过了由德国TÜV机构实施的欧盟承压设备指令(PED-97/23/EC)和(MD-06/42/EC)认证、美国3A机构实施的3-A卫生标准认证、中国安全阀特种制造设备(TS)许可证和中国质量认证中心CQC ISO9001:2008质量管理体系认证等多项国际权威认证。

东正凭借先进的技术、优异的品质和完善的售后服务体系，先后被评定为国家高新技术企业，省著名商标、省科技型企业、创新型企业、专利示范企业、研发中心企业，守合同重信用AAA企业等众多荣誉。

关于东正 About DONJOY

Donjoy was built up in 1993, with registered capital RMB 55,08 millions. We focus on developing high quality PID process controller, the valve positioner, the flow controller, the valve control unit, high purity process control valve, intelligent self-control valve, high purity pump, high purity tubing fitting and pipeline accessories. Donjoy's products and technologies are widely used in biopharmaceutical, food, drink, wine fine chemicals and other industrial fields. Donjoy's innovation solutions meet the growing demand of the industry of biopharmaceutical, food and beverage from the whole world, especially the emerging market.

Raw material, processing technology, welding technology, surface treatment from Donjoy have achieved advanced levels of domestic and foreign market. Donjoy productions according to ASME BPE, EHEDG, FDA and 3A standard, get certificate of PED-97/23/EC and MD-06/42/EC issued by TUV, 3A issued by 3A organization, TS licence and ISO9001:2008.

Donjoy with advanced technology, excellent quality and perfect after-sales service system, has been assessed as the national high-tech enterprises, the Provincial Famous Trademark, the Provincial Science and Technology Enterprises, Innovative Enterprises, Patent Model Enterprises, R & D Center, AAA Credit Enterprises.



创立于2005年现代化工厂
温州滨海经济开发区生产基地
Wenzhou binhai economic development zone production base

DONJOY high-purity valve, pump, control system, pipe and accessories, provide the most excellent solution for various business scopes.



Biopharmaceutical



Dairy



Food



Beverage



Water Processing



Brewing



Fine Chemical

制造与检验 Manufacturing and testing



机器人生产线 Robot production line

全自动弯管设备 Automatic pipe bending equipment

DONJOY以科学技术是第一生产力，也是企业核心竞争力，只有不断投入核心技术研发和创新，不断追求卓越，精益求精、以先进生产设备，严格的质量管理体系，精密的生产检测流程，保证每一款产品优良的性能。

Science and technology constitute a primary productive force, also the core competitive strength of the enterprise. Continuously intensifying the research, development and innovation of core technology, pursuing prominence and keeping improving, ensuring the excellent quality and performance of every single product by advanced production equipment, strict quality control and precise production and inspection procedures.

荣誉与资质

Honor and qualification

	<p>3A</p> <p>东正是美国3A认证组织的金牌赞助商，3A是一个自愿组织，致力于维护公共卫生和奶制品产品质量通过独特的行业监管程序的设备，用于处理乳制品的卫生标准3A认证。 东正通过认证产品，阀门系列55-02-1783、64-00-1784、84-02-1786、85-03-1787、53-06-1782、54-02-1580、68-00-1785，管件(63-03)证书号(1581)等多种规格型号。</p>
	<p>PED/97/23/EC & MD/06/42EC</p> <p>东正通过了TUV 欧共体压力设备97/23/EC质量保证模式H&材料(管件)制造认证。 阀门证书 NO.CE 0036 泵类证书 NO.705201402401-00</p>
	<p>FDA177.2600</p> <p>东正生产的阀门和泵以及流体设备等，与物料接触密封圈全部通过或符合美国食品和药品管理局和联邦法规第21条即，CRF 21 FDA177.2600和FDA177.1550认证，其涵盖： EPDM VITON(FPM) SILICON HNRPTFE橡胶塑料材料等。</p>
	<p>ISO9001/2008</p> <p>东正通过中国质量认证中心CQC，ISO9001-2008/GB/T19001-2008企业质量管理体系认证。其证书编号: 00108Q24215R1M/3302</p>
	<p>卫生许可证</p> <p>东正通过了省卫生厅卫生阀门、卫生管件等检验，且获得了其颁发的证书，其编号: So083。 其许可证为国家出台的生活饮用水卫生监督管理方法证书。</p>
	<p>高新技术企业</p> <p>东正通过多年发展和技术创新已获得了多项国家发明专利，100多项实用新型专利，现已成为国家高新技术企业。</p>
	<p>浙江省著名商标</p> <p>东正09年获得了温州市著名商标，2012年获得了浙江省著名商标。</p>

DONJOY不但拥有以上认证和荣誉，且被评定为省科技型、创新型、专利示范、研发中心、守合同守信用企业等众多的荣誉证书。

高洁净蝶阀 High purity butterfly valve

东正众多的蝶阀技术产品
防混蝶阀、双座蝶阀、单座蝶阀
DONJOY Butterfly valve technology type
Mixing proof butterfly valve
Double seat butterfly
Single seat butterfly



蝶阀不同材质密封性能曲线图
Butterfly valve seal performance diagram for different materials

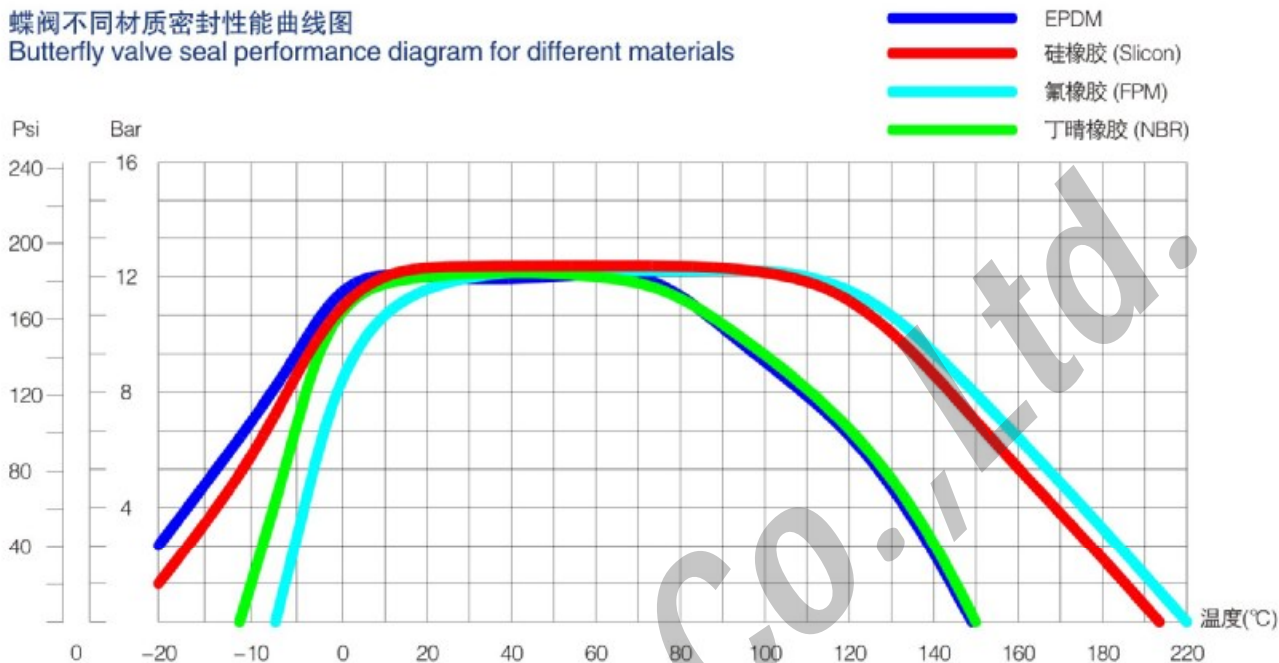

说明：测试条件，介质水 Test conditions: medium water

对介质的耐抗性-体积变化率%
Medium resistance – volume change rate %

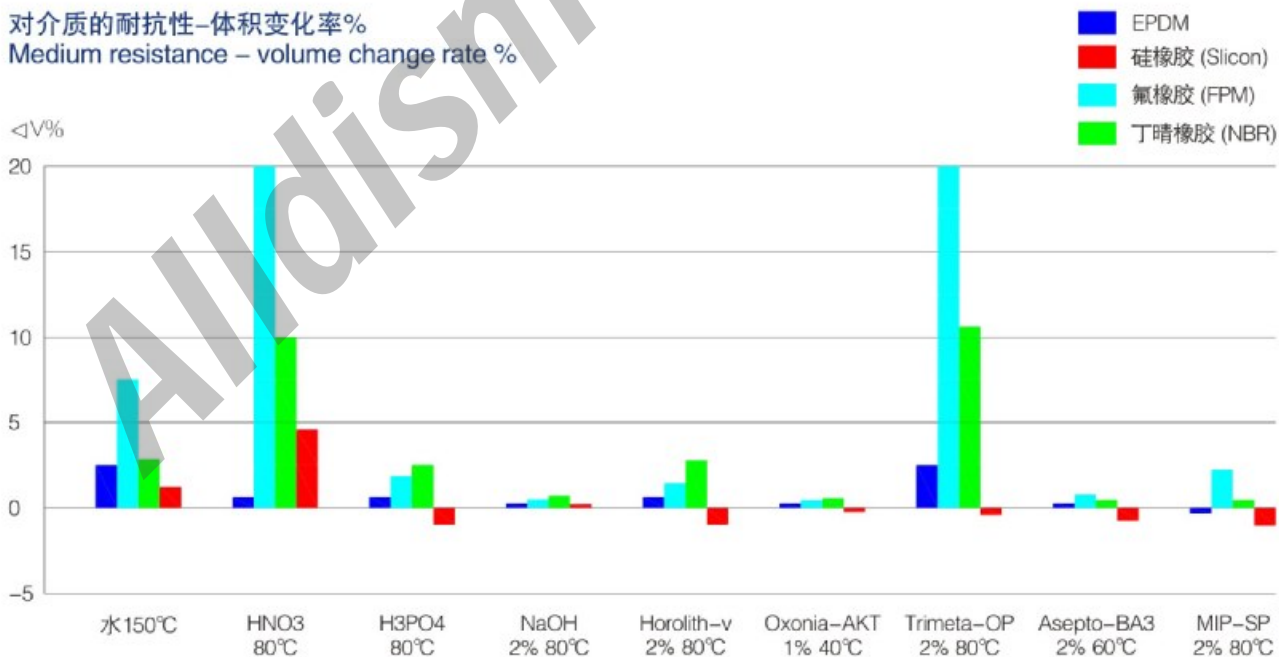

防混蝶阀

Mixing proof butterfly valve

洁净和安全
 一个蝶板二道密封
 泄露看得见
 零的污染风险
 Purity and safety
 One butterfly plate two seal
 Leakage is visible
 Zero risk of contamination



NEW



防混蝶阀+C-TOP
Mixing proof butterfly valve +C-TOP

NEW

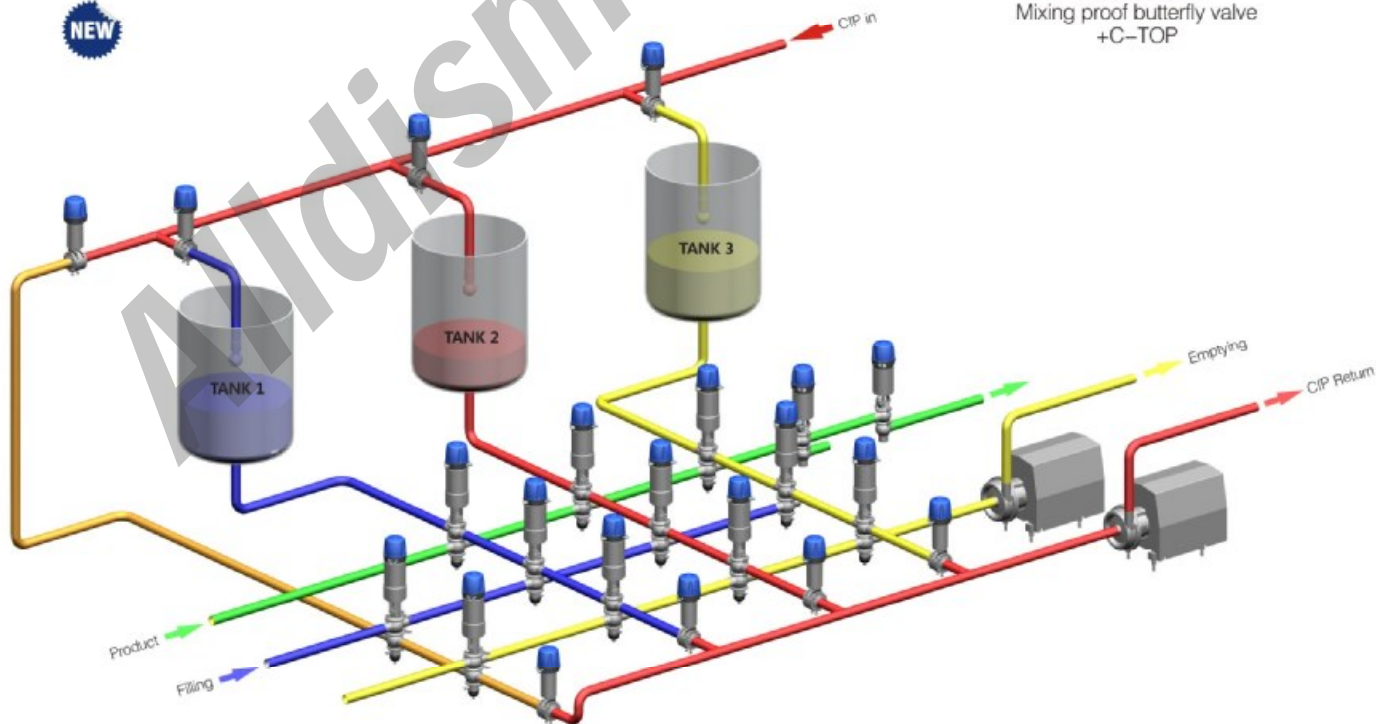

应用领域

防混蝶阀作为一个分离物料的重要过程广泛用于以下多种应用:

- ◆ CIP清洗系统中, 分离清洗溶液
- ◆ 冲洗过程应用
- ◆ 水源管理应用
- ◆ 部分管路关闭来分离物料
- ◆ CIP/气源管理应用(酿酒)
- ◆ 储罐物料分离/CIP
- ◆ 作为在阀矩阵里的CIP回流阀
- ◆ 尤其适用于液体和无悬浮物/颗粒的气体介质。

技术规格

规格: DN50-DN100, 2"-4"

材质: 1.4404/1.4301,304/316L

最高温度: -10°C-130°C

最大压力: 10bar

操作方式: 气动/手动可互换

控制盒: C-TOP基本型, C-TOP+AS-I通讯

密封圈: EPDM(标准)FPM/SILICON/NBR,FDA177.2600

Application

The mixproof butterfly valve as a process element for the separation of media is suitable for a variety of applications:

- ◆ In CIP systems, for separating CIP media
- ◆ In flush-out processes
- ◆ In water management
- ◆ As pipe section shut-off valve for separating media
- ◆ In CIP/gas management (breweries)
- ◆ At storage tanks for separating product/CIP
- ◆ As CIP return valve in a valve matrix
- ◆ Preferably suitable for liquid and gaseous media without suspended matter/particles.

Technical specifications

Size: DN50-DN100, 2"-4"

Material: 1.4404/1.4301, 304/316L

Max temperature: - 10°C - 130°C

Max pressure: 10bar

Operation: pneumatic/manual interchangeable

Control box: C-TOP basic, C-TOP+AS-I communication

Seal: EPDM (standard) FPM/SILICON/NBR, FDA177.2600

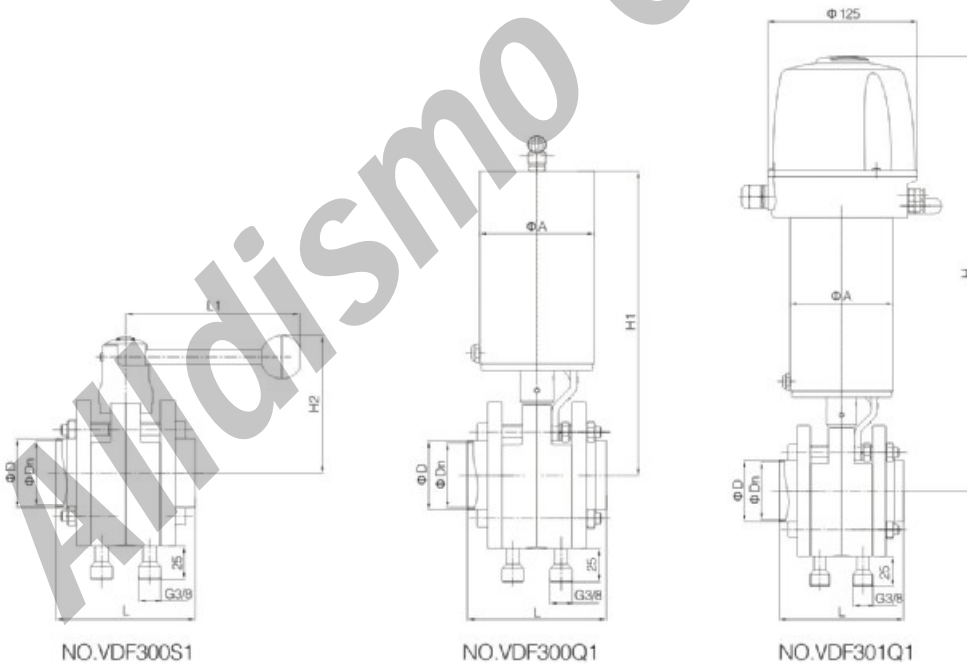

INCH

SIZE	Dn	D	L	L1	H	H1	H2	A
2"	47.8	50.8	104	133	377	239	102	86
2.5"	59.5	63.5	112	144	440	305	106.5	113
3"	72.2	76.2	112	144	448	313	113	113
4"	97.6	101.6	128	160	463	328	131	113

DIN

SIZE	Dn	D	L	L1	H	H1	H2	A
DN50	49	52	104	133	377	239	102	86
DN65	66	70	112	144	445	310	111.5	113
DN80	81	85	120	160	453	318	121	113
DN100	100	104	128	160	463	328	131	113

双座蝶阀A型

Double seat butterfly valve (type A)

防混蝶阀/双座蝶阀 Double Seat Mixproof Butterfly Valve

工作原理图 Operating principle

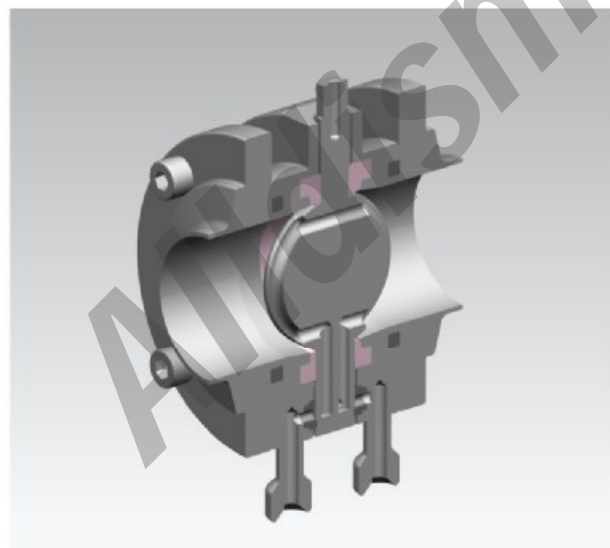
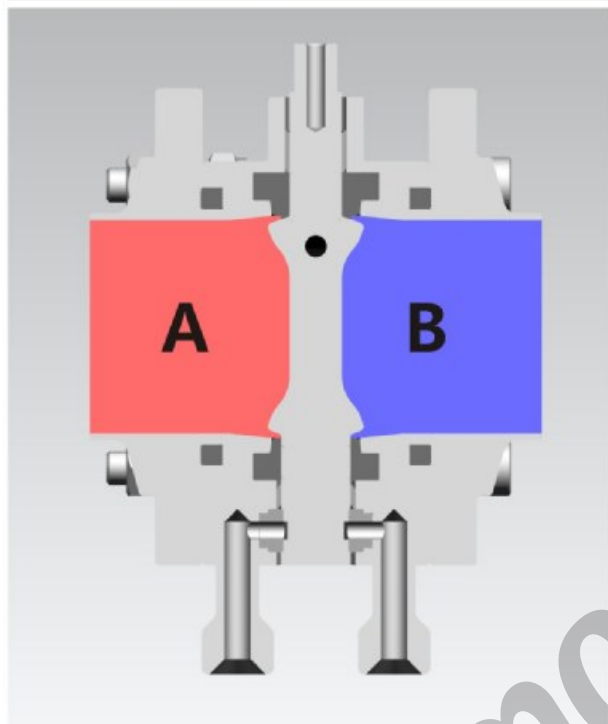

阀门开启的位置

当阀门处于开启的位置，排泄腔通往外部大气的路径就关闭了。

Valve Open position

When the valve open, the leakage paths towards the atmosphere are closed.

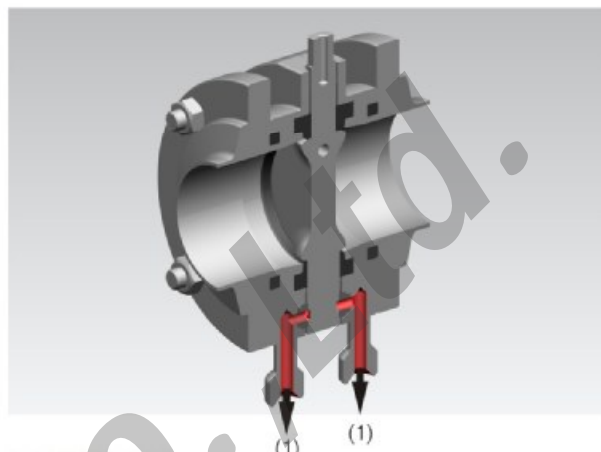

阀门关闭的位置

当阀门处于未启动的位置(OFF位置)，介质A和介质B是分开的。在这种情况下，排泄腔是开启的和外部大气相通。切换之后，在阀门排泄腔内的液体可以通过重力排出。这个连接也可以作为排泄指标。

Valve Closed position

When the valve is in the non-actuated position (OFF position), medium A and medium B are reliably separated. The leakage cavity open towards the atmosphere in this case. After switching, the medium in the valve disk leakage areas can drain by gravity (1). The connection is also served as a leakage indicator.

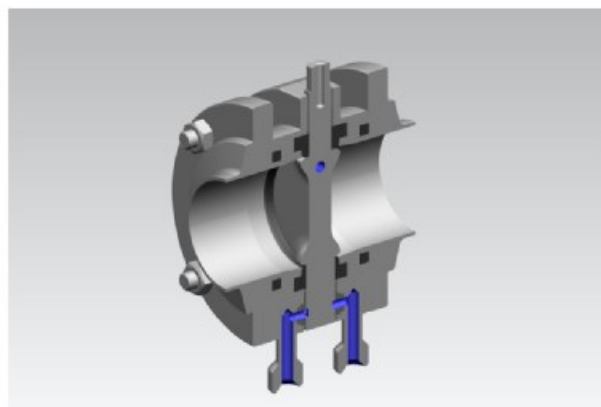

清洗排泄腔

这个排泄腔在需要的情况下是可以清洗和冲洗的。因此，两个连接口可以结合成一个CIP回路，当阀门关闭时，就可以进行冲洗。供应管道的清洗压力应略小于内部过程压力(出于卫生考虑)。

Cleaning of the leakage cavity

The leakage paths can be cleaned/flushed if necessary. For this purpose, the two cleaning connections can be integrated into the CIP circuit. It can be flushed when the valve is closed. The cleaning pressure in the supply line should be slightly lower than the inside process pressure (hygienic aspects).

双座蝶阀B型

Double seat butterfly valve (type B)

应用

双座蝶阀广泛用于食品，制药和精细化工行业中大多数的流体过程应用。这款排泄蝶阀提供了简易及安全的物料分离方式以便在密封圈损坏的情况下也能防止物料的意外混合。它最常用于隔离那些需要安全分离的物料以及单组CIP清洗(不是阀阵组件)，或者在阀阵组件终端(例如 CIP回程)或者 CIP溶液输入到罐内(通过清洗球)。

Application

Double seat butterfly valves can be used in food-processing, pharmacy and chemical industries. Leakage Butterfly Valve offers an easy and safe separation of products and prevents accidental mixing in case of gasket failure. The most usual applications are the ones that require safe separation of the product and CIP solutions in a single point (not in manifolds), or at the end of a manifold (e.g. CIP return) or entry of a CIP solution into a tank (through a spray ball).

设计和特点 Design and features

紧凑型设计

两边阀体可互换(无论何种连接)

连接:

DIN11850 焊接,

DIN32676卡箍,

DIN11851螺纹,

焊接 ASME BPE,

卡箍 ASME BPE

Compact and robust design.

Interchangeable half-bodies (any connection type).

Connections:

Weld DIN 11850

CLAMP DIN 32676

Thread DIN 11851

Weld ASME BPE,

Clamp ASME BPE



双座蝶阀B型

Double seat butterfly valve (type B)

材质 Materials

与物料接触AISI 316L/1.4404
 其他部分: AISI 304
 密封: EPDM FDA177.2600
 内表面粗糙度Ra≤0.8微米
 外表面精加工

Parts in contact with the medium AISI 316L/1.4404
 Other: AISI 304
 Gasket: EPDM FDA 177.2600
 Internal surface finish: Ra ≤ 0.8 μm
 External surface finish: CNC Machined

选项 Options

垫片: NBR, MVQ & FPM
 连接: SMS, RJT, DIN, 3A, ISO
 双作用的气动执行机构
 感应式位置传感器
 C-TOP控制头
 位置传感器

Gaskets: NBR, MVQ & FPM
 Connections: SMS, RJT, DIN, 3A, ISO
 Air/air pneumatic actuator
 Inductive position sensors
 C-TOP control head
 Position sensors

防混蝶阀/双座蝶阀 Double seat mixproof Butterfly Valve

工作原理

这款排泄蝶阀提供了密封双保险: 两只阀门同时由一个执行器驱动。当这两只阀门关闭时, 会有一个阀腔在它们之间。这个阀腔压力低于标准大气压, 以至于它由外部开启, 从而, 在任何密封圈损坏情况下, 液体物料的泄漏将指示出任何可能的物料意外混合。通过检漏探测的方式来监督密封圈的状况, 其他的探测(更高级的)控制着进入的清洗溶液以防任何形势的阀腔污染。

Operating principle

It provides double safety: the two butterfly valves are simultaneously actuated by only one actuator. When the two valves are closed, there is a chamber between them. The chamber is under atmospheric pressure as it open to the exterior, thus, in case of failure of any of the two gaskets, leakage of the liquid product will indicate any possible mixing of products. The state of the gaskets is supervised by means of either of the leakage detectors. The other detector (superior) controls the entry of the cleaning solution to prevent any kind of contamination in the chamber. These 2 leakage detectors provide optimal protection and enable cleaning of the intermediate chamber.

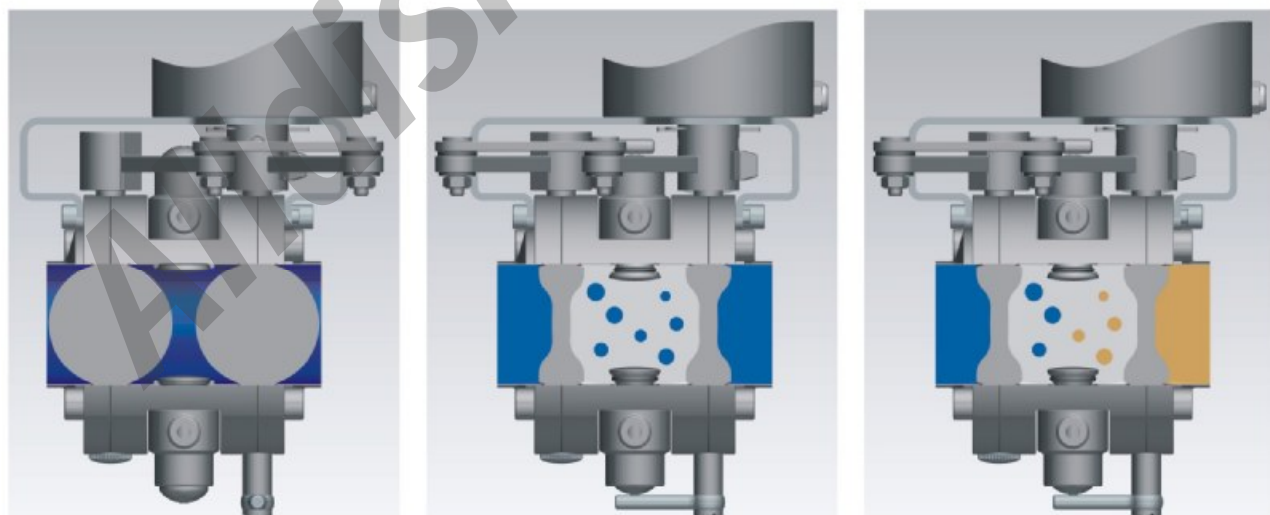

阀门开启 ON
 物料 Medium

阀门关闭 OFF
 CIP液体 CIP Liquid

清洁腔/检漏器
 Clean chamber / detector

观察内泄露
阀腔可清洗
零污染风险

Internal leakage can be observed
Valve chamber can be flushed
Zero risk of contamination

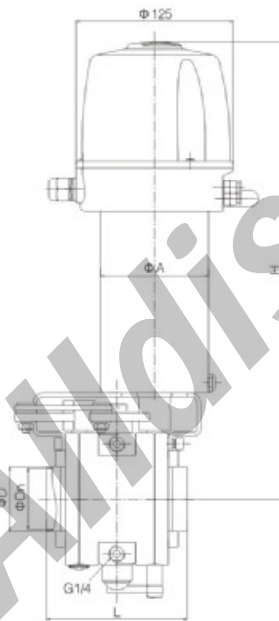

NO.VDF401Q1

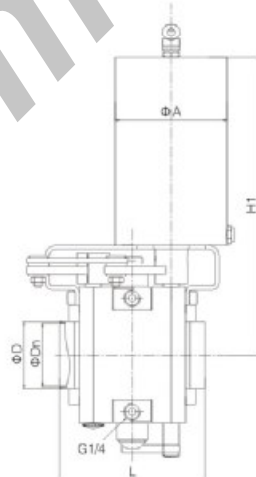

NO.VDF400Q1

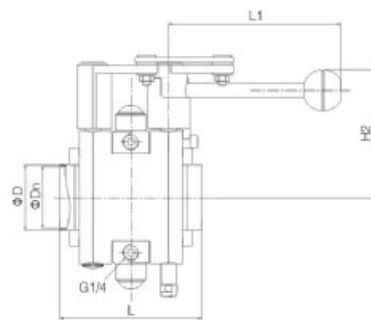

NO.VDF400S1

INCH

SIZE	Dn	D	L	L1	H	H1	H2	A
2"	47.8	50.8	112	133	369	234	102	86
2.5"	59.5	63.5	126	144	433	298	106	113
3"	72.2	76.2	141	144	440	305	113	113
4"	97.6	101.6	170	160	455	320	130	113

DIN

SIZE	Dn	D	L	L1	H	H1	H2	A
DN50	49	52	112	133	369	234	102	86
DN65	66	70	126	144	438	303	112	113
DN80	81	85	146	160	445	310	118	113
DN100	100	104	170	160	455	320	130	113

卫生级蝶阀 Butterfly valve

DONJOY 创新设计
专利保护
Innovative design
Patent protection

应用 Applications

- ◆ 无论手动或者自动操作，都可以用到食品加工，制药和化工等工业流体产品应用中。
- ◆ Butterfly valves, no matter manually or automatically, can be used in food-processing, pharmacy and chemical industries.

工作原理 Operating principles

- ◆ 可以通过执行器自动操作也可用手柄手动操作。
- ◆ 手柄控制阀门“开”和“关闭”的位置，当然也可以调节到其他间的位置。
- ◆ 执行器把活塞的轴向运动转换成90度旋转运动，传输给蝶阀。
- ◆ The butterfly valves can be operated automatically through actuator or manually with the handle.
- ◆ the handle blocks the valve in the "open" or "closed" position, certainly there are the other position available.
- ◆ the actuator push piston of axial movement into 90 degree so that it controls butterfly valve.



技术规格

- ◆最大压力：10bar 1/2"–12", DN10–DN300, 5bar(DN200/300)
- ◆最小压力：0.2bar p.abs
- ◆工作温度：–10°C+120°C(EPDM)

设计和特点

- ◆简洁有活力的设计
- ◆多位手柄：塑料=1/2"–4", 不锈钢=1/2"–6"
- ◆拉杆手柄尺寸到DN25/1"至DN300/12"
- ◆手动手柄和气动或电动执行器可互换
- ◆PED97/23EC认证
- ◆FDA.177.2600密封认证
- ◆任何连接方式的阀体都可以进行更换

应用Applications

- ◆蝶板：AISI 316L/304(锻造)
- ◆阀体：AISI 316L/304(锻造)
- ◆垫圈和密封圈：EPDM根据FDA177.2600
- ◆手柄：AISI 304/PP
- ◆表面处理：Ra≤0.8
- ◆Disc: AISI 316L/304(forged)
- ◆Valve body: AISI 316L/304(forged)
- ◆Washer and gasket: EPDM conforms to PFA 177.2600
- ◆Handle: AISI 304/PP
- ◆Surface finishing: Ra≤0.8

选项 Options

- ◆垫圈材质有NBR, MVQ(硅胶)或FPM(氟橡胶), 它们都符合FDA177.2600
- ◆连接：焊接、卡箍、螺纹、单焊接单螺纹、法兰式、DIN、SMS、RJT、ISO、IDF、3A
- ◆手柄：二定位、三定位、四定位拉杆手柄、多位手柄、多位不锈钢手柄
- ◆执行器：不锈钢气动执行器、卧式气动执行器、电动执行器
- ◆控制：位置传感器、C-TOP控制器、C-TOP控制器(AS-I)
- ◆智能阀门定位器：电流信号4–20mA(0–20mA), 电压信号0–5V; 总线协议DEVICENET
- ◆Gaskets are available in NBR, MVQ or FPM, which all confirm to standard of FDA177.2600
- ◆Connection: weld, clamp, thread, weld thread, flange, DIN, SMS, RJT, ISO, IDF, 3A
- ◆Handle: two-position handle, three-position handle, four-position pull handle, multi-position plastic handle and multi-position stainless steel handle.
- ◆Actuator: pneumatic stainless steel actuator, pneumatic aluminum actuator, electric actuator
- ◆Control: sensor, C-TOP, c-top controller(AS-I)
- ◆Intelligent controller: Current signal 4–20mA(0–20mA), Voltage signal 0–5V, Device net but control

操作扭矩 Operating Torque(N.M)

操作扭矩(N.M) Operating Torque(n.m)	25–1"	40–1½"	50–2"	2½"	65	3"	80	100–4"	125	150
	3	4	5	10	12	14	18	25	40	55

在压力10Kgrs/cm²下检测 Test under pressure of 10Kgrs cm²

Technical specifications

- ◆Max. Pressure: 10bar 1/2"–12", DN10–DN300, 5bar(DN200/300)
- ◆Min.pressure: 0.2bar p.abs
- ◆Operating temperature: –10°C to +120°C(EPDM)

Design and features

- ◆Compact and robust design
- ◆Multi-position handle: Plastic type for 1/2"–4", Stainless steel type for 1/2"–6"
- ◆Pull handle is suitable up to DN25/1" to DN300/12" valve
- ◆Manual handle, pneumatic actuator and electric actuator can be exchangeable with each other
- ◆PED97/23EC
- ◆FDA.177.2600
- ◆The valve body can be changeable with any kind of connection



蝶阀 Butterfly valve



不锈钢多位
手柄+锁
Multi-position
stainless steel
handle+ lock
SIZE: 1"-4"



不锈钢多位
手柄蝶阀
Multi-position
stainless steel
handle
butterfly valve
SIZE:
1"-6", DN25-DN150



拉杆式
手柄蝶阀
Pull handle
butterfly valve
SIZE:
1"-12", DN25-DN300



多位塑料
手柄蝶阀
Multi-position
plastic handle
butterfly valve
SIZE:
1"-4", DN25-DN100



三通蝶阀
Three-way
butterfly valve
SIZE:
1"-4", DN25-DN100



手动蝶阀+
位置传感器
Manual butterfly valve
+position sensor
SIZE:
1"-6", DN25-DN150



气动蝶阀 基本型
Pneumatic butterfly
valve (basic type)

Size: 1"-12", DN25-DN300



气动蝶阀+定位器
Pneumatic butterfly
valve + Positioner

模拟信号
输入: 0/4-20mA, 0-5/10V
输出: 0/4-20mA, 0-5/10V
DEVICE NET BUS 总线通讯
电源: DC 24V

Analog signal
Input: 0/4-20mA, 0-5/10V
Output: 0/4-20mA, 0-5/10V
DEVICE NET BUS
Power supply: DC 24V



气动蝶阀+位置传感器
Pneumatic butterfly
valve + position sensor

传感器: PNP NPN
Sensor: PNP NPN



气动蝶阀+C-TOP
Pneumatic butterfly
valve + C-TOP

接线端子连接
AS - I BUS 总线通讯
电源: DC 24V

Terminal connection
AS - I BUS DEVICE NET
Power supply: DC 24V

蝶阀 Butterfly valve



电动蝶阀
Electric butterfly valve

AC 220/110V DC 24V

功能：开关型、智能型、位置反馈型

Functions: on/off, intelligent, position sensor



气动蝶阀+MINIC-TOP
Pneumatic butterfly valve + MINIC-TOP

SIZE: 1"-2"

气动三片蝶阀+位置传感器
Pneumatic 3PC butterfly valve + sensor

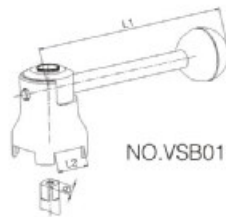
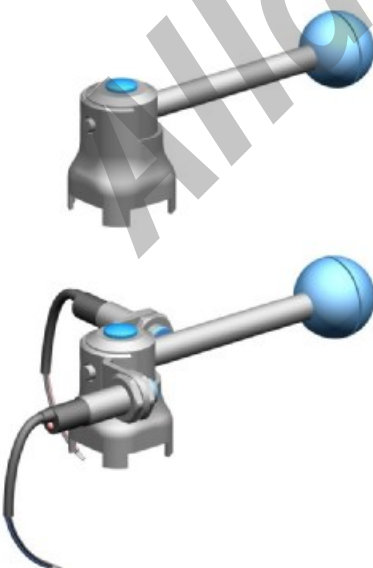

NO.VSB01

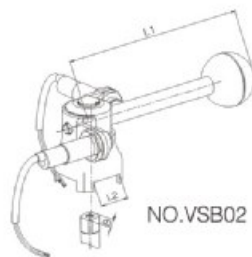

NO.VSB02

NO.VSB01
拉式手柄 Pull handle

SIZE	L1	L2	B	
DN10-DN40	0.5'-1.5"	126	20.2	8
DN50	2"	133	22.2	10
DN65	2.5'-3"	144	22.2	10
DN80-DN100	3.5'-4"	160	22.2	11
DN125-DN150	5'-6"	220	30.2	14
DN200-DN300	8'-12"	284	30.2	14

NO.VSB02
拉式手柄带传感器 Pull handle

SIZE	L1	L2	B	
DN10-DN40	0.5'-1.5"	126	20.2	8
DN50	2"	133	22.2	10
DN65	2.5'-3"	144	22.2	10
DN80-DN100	3.5'-4"	160	22.2	11
DN125-DN150	5'-6"	220	30.2	14
DN200-DN300	8'-12"	284	30.2	14

各种手柄设计
Various handles

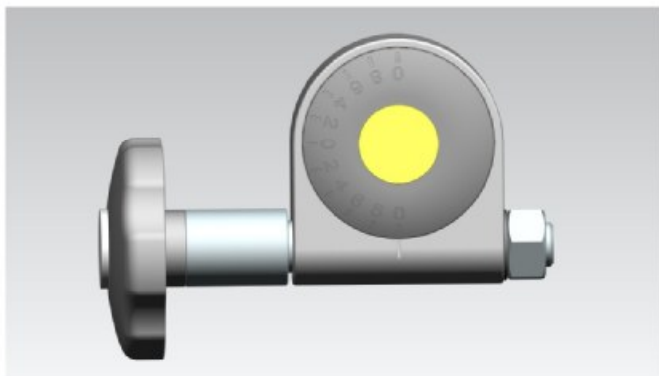

NEW

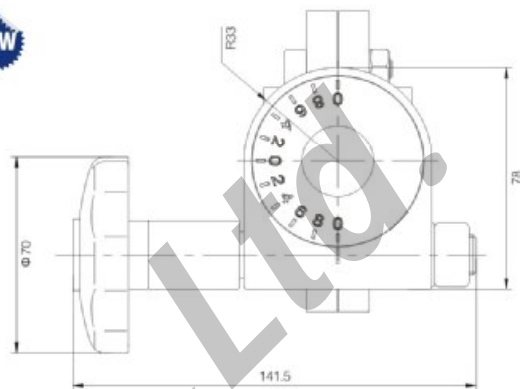

微调手柄尺寸图
Fine-tuning handle size drawing
NO.VSB05

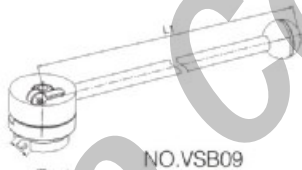

NO.VSB09

NO.VSB09
多位手柄Multi-position handle

SIZE	L1	L2	B	
DN125-DN150	5'-6"	257	30.2	14
DN200-DN300	8'-12"	397	30.2	14

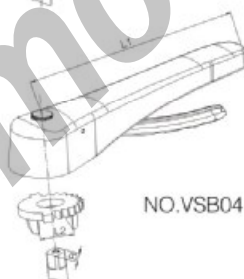
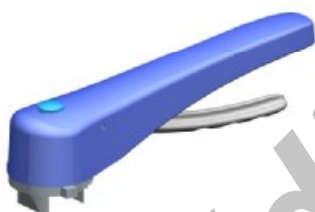

NO.VSB04

NO.VSB04
09款多位塑料手柄
Multi-position handle(Plastic)

SIZE	L1	L2	B	
DN10-DN40	0.5'-1.5"	164	20.2	8
DN50-DN65	2'-3"	164	22.2	10
DN80-DN100	3.5'-4"	164	22.2	11

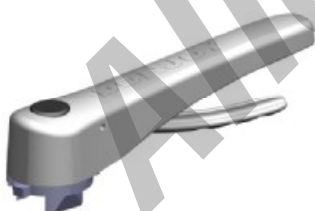

NO.VSB06

NO.VSB06
11款多位不锈钢手柄
Multi-position handle(Stainless steel)

SIZE	L1	L2	B	
DN10-DN40	0.5'-1.5"	166	20.2	8
DN50-DN65	2'-3"	166	22.2	10
DN80-DN100	3.5'-4"	166	22.2	11
DN125-DN150	5'-6"	166	30.2	14



NO.VSB08

NO.VSB08
13款多位不锈钢手柄(带锁)
Multi-position handle(Stainless steel)

SIZE	L1	L2	B	
DN15-DN40	0.5'-1.5"	155	20.2	8
DN50-DN65	2'-3"	155	22.2	10
DN80-DN100	3.5'-4"	155	22.2	11

蝶阀 Butterfly valve



微调式手轮蝶阀 Fine tuning handwheel butterfly valve

微调蝶阀具备标准蝶阀所有的功能和特点，该蝶阀具有非常灵活的流量调节装置，开关量可调节，阀位可通过刻度表反馈
连接方式：卡箍、焊接、螺纹等

Fine tuning the standard butterfly valve butterfly valve with all the functions and features, The butterfly valve has a very flexible flow regulating device, the switch can be adjusted by scale sheet valve position feedback
Connection: clamp, welding, thread, etc.

技术规格 Technical specifications

SIZE: 1"-6", DN25-DN150

材质: 304/316L

连接方式: 卡箍、焊接、螺纹等

Material: 304/316L

Connection: clamp, welding, thread, etc.

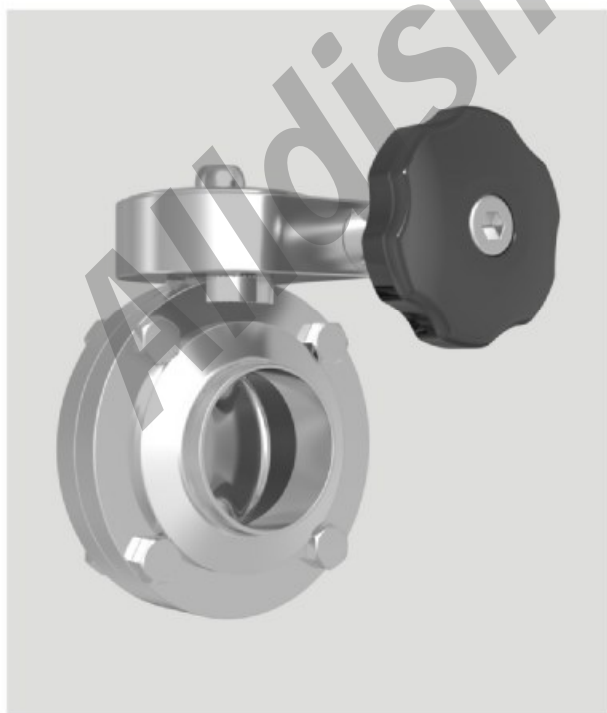

NEW



粉体蝶阀 Powder butterfly valve

The butterfly valve is designed application delivery split open and close the valve, the principle of using compressed air to achieve seal. This type is available for ultra-small torque which normal butterfly valve cannot do.
Design specifications: DN100-DN300, 4"-12"
Material: 316L
Seal FPM / EPDM FDA177.2600
Execution modes: manual and pneumatic

工作原理 Working principle

阀门开启密封失效，但不会外泄。
阀门关闭气体密封，保持了没有密封摩擦。
Valve open seal failure, but will not be disclosed.
Gas can do seal once valve closed, to remain no seal friction.

技术优势 Technical advantages

开启和关闭密封不会产生摩擦，因此无需担心密封因摩擦产生的污染物。
Open and close valve the seal does not produce friction, there is no fear of contamination generated by friction seal.

如需更详细资料，请联系DONJOY

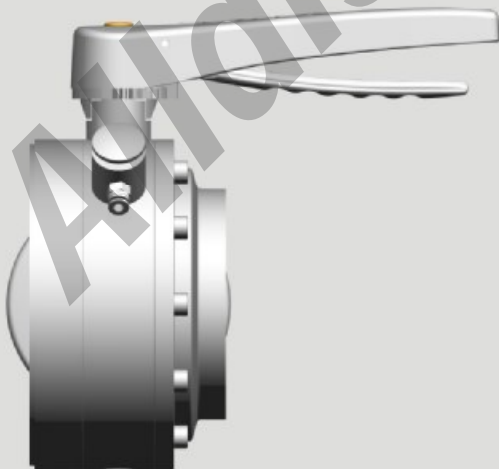

蝶阀尺寸图

Dimension of butterfly valve

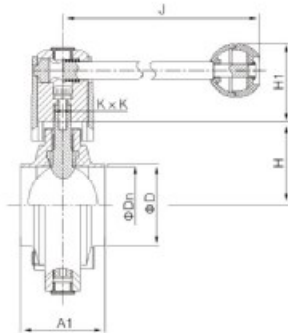

拉动手柄蝶阀
Manual butterfly valve
NO.VDF100S1

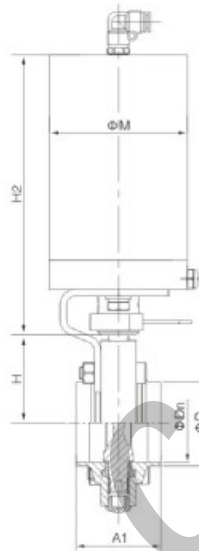

不锈钢气动蝶阀
SS Pneumatic butterfly valve
NO.VDF100Q1

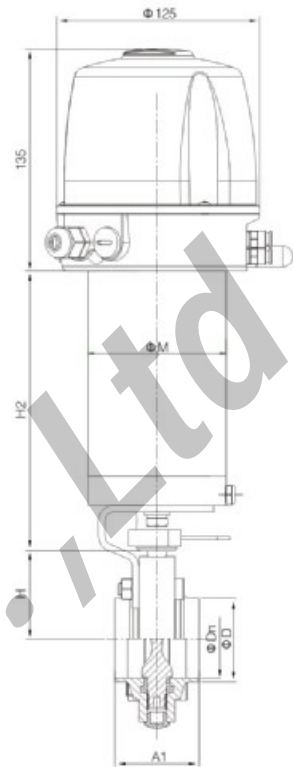

带智能头气动蝶阀
Pneumatic butterfly valve+C-TOP
NO.VDF101Q1

蝶阀(DIN) Butterfly valve (DIN)

SIZE	Dn	D	J	H	H1	H2	M	A1
DN10	10	13	126	40	43.5	172.5	86	50
DN15	15	18/19	126	40	43.5	172.5	86	50
DN20	19	22/23	126	40	43.5	172.5	86	50
DN25	25	28/29	126	40	43.5	172.5	86	50
DN32	31	34/35	126	44.5	43.5	172.5	86	50
DN40	37	40/41	126	46.5	43.5	172.5	86	50
DN50	49	52/53	133	54.5	47.5	172.5	86	52
DN65	66	70	144	64	47.5	172.5	86	56
DN80	81	85	160	70.5	50	172.5	86	60
DN100	100	104	160	81	50	172.5	86	64
DN125	125	129	257	94.5	52.5	248	113	80
DN150	150	154	257	110	52.5	285	133	90
DN200	200	204	397	145	52.5	306	166	90
DN250	250	254	397	174	52.5	306	166	90
DN300	300	304	397	174	52.5	306	166	90

蝶阀(INCH) Butterfly valve(INCH)

SIZE	Dn	D	J	H	H1	H2	M	A1
1/2"	9.7	12.7	126	40	43.5	172.5	86	50
3/4"	16.1	19.1	126	40	43.5	172.5	86	50
1"	22.4	25.4	126	40	43.5	172.5	86	50
1 1/8"	28.8	31.8	126	40	43.5	172.5	86	50
1 1/2"	35.1	38.1	126	44.5	43.5	172.5	86	50
Ø45	41	45	126	46.5	43.5	172.5	86	50
Ø48	45	48	126	48.5	43.5	172.5	86	52
2"	47.8	50.8	133	52.5	47.5	172.5	86	52
Ø57	53	57	144	54	47.5	172.5	86	52
2 1/2"	59.5	63.5	144	59	47.5	172.5	86	56
3"	72.2	76.2	144	65.5	47.5	172.5	86	56
3.5"	85	89	144	72	50	172.5	86	60
4"小	97.6	101.6	144	79	50	172.5	86	64
4"大	97.6	101.6	160	81	50	172.5	86	64
108	104	108	160	82.5	50	172.5	86	64
114.3	110.3	114.3	160	82.5	52.5	248	113	64
133	127	133	257	94.5	52.5	248	113	80
6"	146.8	152.8	257	110	52.5	285	133	90
159	153	159	257	110	52.5	285	133	90
8"	197.6	203.2	397	145	52.5	306	166	90
219	211	219	397	145	52.5	306	166	90
10"	247.2	254	397	174	52.5	306	166	90

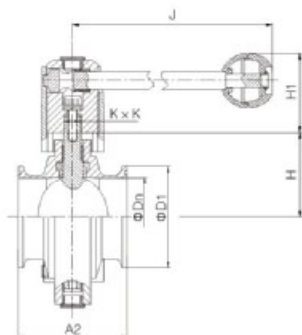

拉式手柄蝶阀
Manual butterfly valve
NO.VDF110S1

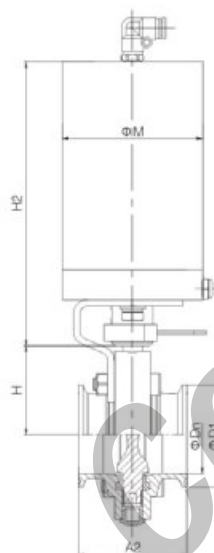

不锈钢气动蝶阀
SS Pneumatic butterfly valve
NO.VDF110Q1

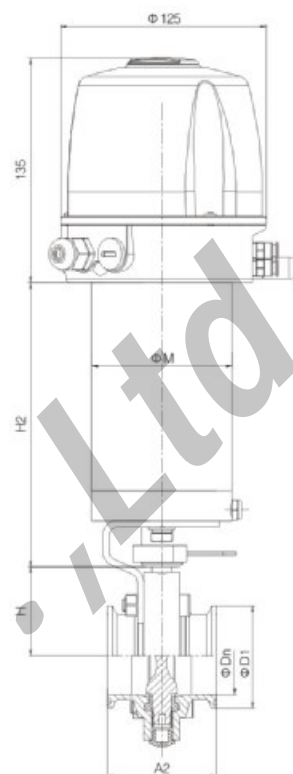

带智能头气动蝶阀
Pneumatic butterfly valve+C-TOP
NO.VDF111Q1

蝶阀(DIN) Butterfly valve (DIN)

SIZE	Dn	D1	J	H	H1	H2	M	A2
DN10	10	34	126	40	43.5	172.5	86	66
DN15	15	34	126	40	43.5	172.5	86	66
DN20	19	34	126	40	43.5	172.5	86	66
DN25	25	50.5	126	40	43.5	172.5	86	66
DN32	31	50.5	126	44.5	43.5	172.5	86	66
DN40	37	50.5	126	46.5	43.5	172.5	86	70
DN50	49	64	133	54.5	47.5	172.5	86	76
DN65	66	91	144	64	47.5	172.5	86	80
DN80	81	106	160	70.5	50	172.5	86	84
DN100	100	119	160	81	50	172.5	86	104
DN125	125	144.5	257	94.5	52.5	248	113	122
DN125	125	155	257	94.5	52.5	248	113	122
DN150	150	167	257	110	52.5	285	133	146
DN150	150	183	257	110	52.5	285	133	146
DN200	200	217.4	397	145	52.5	306	166	166
DN200	200	233.5	397	145	52.5	306	166	166
DN250	250	268	397	174	52.5	306	166	167
DN300	300	319	397	174	52.5	306	166	146

蝶阀(INCH) Butterfly valve(INCH)

SIZE	Dn	D1	J	H	H1	H2	M	A2
1/2"	9.7	25.4	126	40	43.5	172.5	86	66
3/4"	16.1	25.4	126	40	43.5	172.5	86	66
1"	22.4	50.5	126	40	43.5	172.5	86	66
1 1/4"	28.8	50.5	126	40	43.5	172.5	86	66
1 1/2"	35.1	50.5	126	44.5	43.5	172.5	86	70
phi 45	41	64	126	46.5	43.5	172.5	86	74
phi 48	45	64	126	48.5	43.5	172.5	86	76
2"	47.8	64	133	52.5	47.5	172.5	86	76
phi 57	53	77.5	144	54	47.5	172.5	86	76
2 1/4"	59.5	77.5	144	59	47.5	172.5	86	80
3"	72.2	91	144	65.5	47.5	172.5	86	84
3.5"	85	106	144	72	50	172.5	86	86
4"小	97.6	119	144	79	50	172.5	86	104
4"大	97.6	119	160	81	50	172.5	86	104
108	104	119	160	82.5	50	172.5	86	106
114.3	110.3	130	160	82.5	52.5	248	113	106
133	127	144.5	257	94.5	52.5	248	113	122
6"	146.8	167	257	110	52.5	285	133	146
159	153	183	257	110	52.5	285	133	146
8"	197.6	217.4	397	145	52.5	306	166	166
219	211	233.5	397	145	52.5	306	166	166
10"	247.2	268	397	174	52.5	306	166	167

蝶阀尺寸图

Dimension of butterfly valve

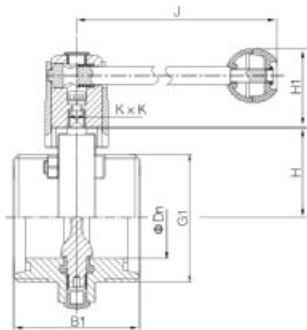

拉式手柄蝶阀
Manual butterfly valve
NO.DIN-VDF130S1

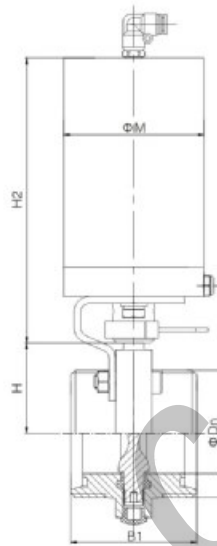

不锈钢气动蝶阀
SS Pneumatic butterfly valve
NO.DIN-VDF130Q1

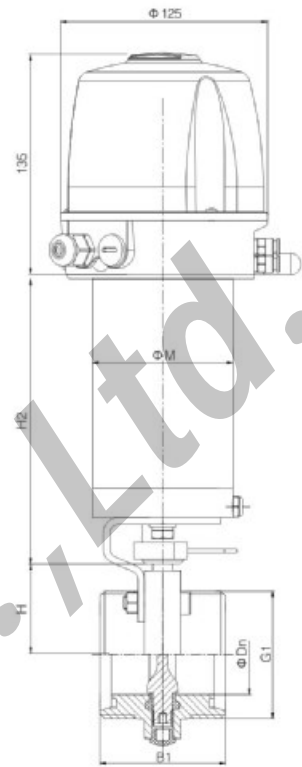

带智能头气动蝶阀
Pneumatic butterfly valve+C-TOP
NO.DIN-VDF131Q1

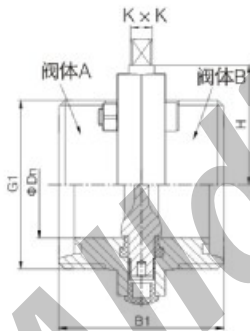

螺纹式 MALE/MALE(DIN)
NO.DIN-VDF130XX

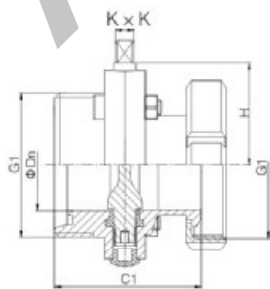

单螺纹单螺母式 MALE/NUT(DIN)
NO.DIN-VDF120XX-23

蝶阀(DIN) Butterfly valve (DIN)

SIZE	Dn	K x K	H	H1	H2	M	B1	C1	螺纹Male(DIN) G1
DN10	10	8 x 8	40	43.5	172.5	86	66	75	Rd28 x 1/8
DN15	15	8 x 8	40	43.5	172.5	86	66	75	Rd34 x 1/8
DN20	19	8 x 8	40	43.5	172.5	86	66	76	Rd44 x 1/6
DN25	25	8 x 8	40	43.5	172.5	86	66	80	Rd52 x 1/6
DN32	31	8 x 8	44.5	43.5	172.5	86	70	85	Rd58 x 1/6
DN40	37	8 x 8	46.5	43.5	172.5	86	74	88	Rd65 x 1/6
DN50	49	10 x 10	54.5	47.5	172.5	86	76	92	Rd78 x 1/6
DN65	66	10 x 10	64	47.5	172.5	86	80	100	Rd95 x 1/6
DN80	81	11 x 11	70.5	50	172.5	86	84	109	Rd110 x 1/4
DN100	100	11 x 11	81	50	172.5	86	104	128	Rd130 x 1/4
DN125	125	14 x 14	94.5	52.5	248	113	130	139	Rd160 x 1/4
DN150	150	14 x 14	110	52.5	285	133	150	157	Rd190 x 1/4

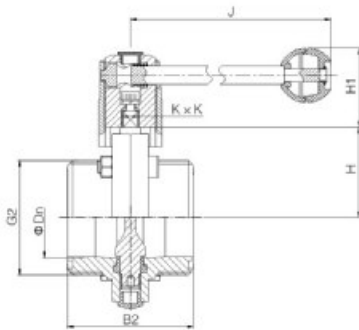

拉手柄蝶阀
Manual butterfly valve
NO.SMS-VDF130S1

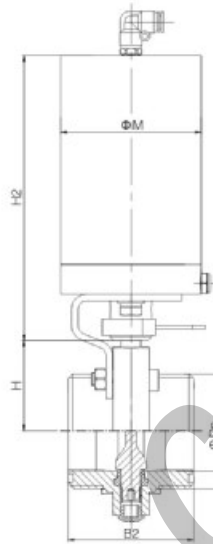

不锈钢气动蝶阀
SS Pneumatic butterfly valve
NO.SMS-VDF130Q1

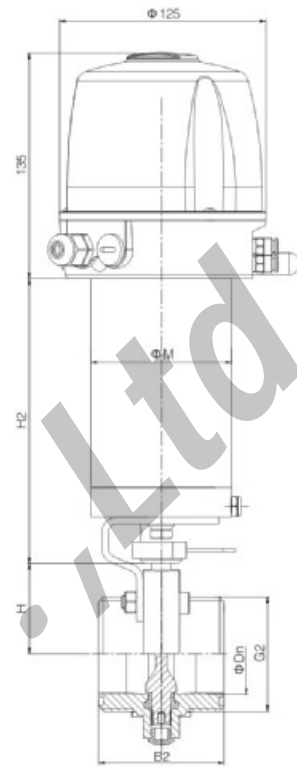

带智能头气动蝶阀
Pneumatic butterfly valve+C-TOP
NO.SMS-VDF131Q1

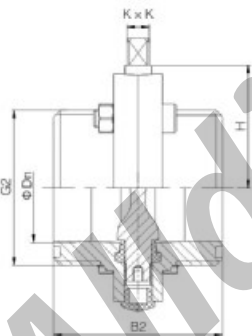

螺纹式MALE/MALE(SMS)
NO.SMS-VDF130XX

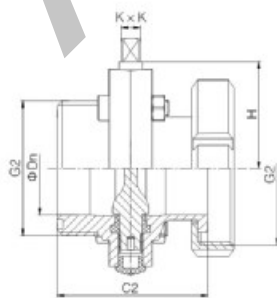

单螺纹单螺母式MALE/NUT(SMS)
NO.SMS-VDF1Z0XX-23

蝶阀(SMS) Butterfly valve (SMS)

SIZE	Dn	K x K	H	H1	H2	B2	C2	螺纹Male(SMS)
								G2
3/4"	16	8 x 8	40	43.5	172.5	66	70	Rd36 x 1/8
1"	22.4	8 x 8	40	43.5	172.5	66	73	Rd40 x 1/6
1 1/4"	28.8	8 x 8	40	43.5	172.5	66	78	Rd48 x 1/6
1 1/2"	35.1	8 x 8	44.5	43.5	172.5	70	80	Rd60 x 1/6
2"	47.8	10 x 10	52.5	47.5	172.5	76	84	Rd70 x 1/6
2 1/2"	59.5	10 x 10	59	47.5	172.5	80	89	Rd85 x 1/6
3"	72.2	10 x 10	65.5	47.5	172.5	84	91	Rd98 x 1/6
3.5"	85	11 x 11	72	50	172.5	86	94	Rd105 x 1/6
4"小	97.6	11 x 11	79	50	172.5	104	105	Rd125 x 1/4
4"大	97.6	11 x 11	81	50	172.5	104	105	Rd132 x 1/4

蝶阀尺寸图

Dimension of butterfly valve

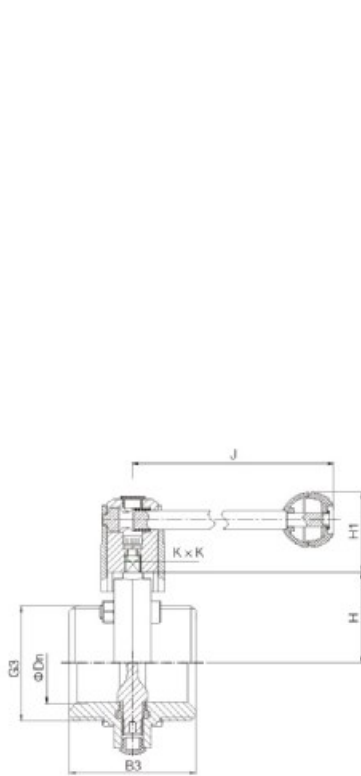

拉式手柄蝶阀
Manual butterfly valve
NO.3A-VDF130S1

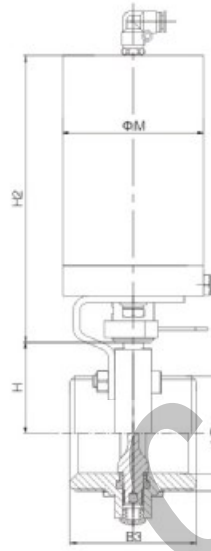

不锈钢气动蝶阀
SS Pneumatic butterfly valve
NO.3A-VDF130Q1

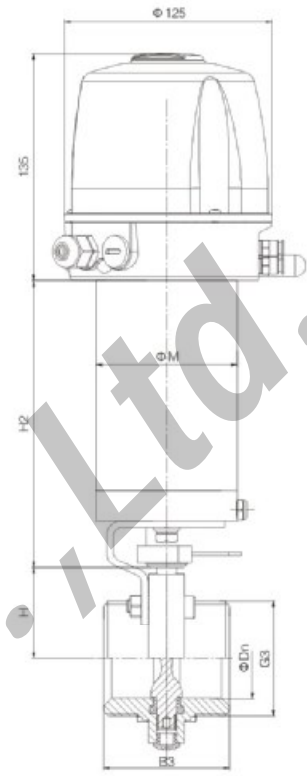

带智能头气动蝶阀
Pneumatic butterfly valve+C-TOP
NO.3A-VDF131Q1

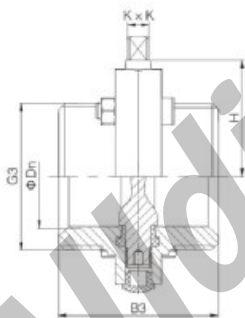

螺纹式MALE/MALE(3A)
NO.3A-VDF130XX

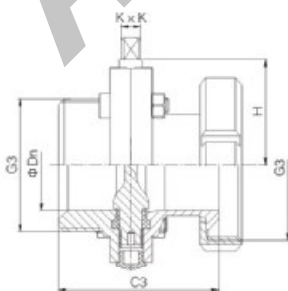

单螺纹单螺母式MALE/NUT(3A)
NO.3A-VDF1Z0XX-23

蝶阀(3A) Butterfly valve (3A)

SIZE	Dn	K x K	H	H1	H2	B3	C3	螺纹Male(3A)
								G3
1"	22.1	8 x 8	40	43.5	172.5	66	93	37.1 x 1/8Acme
1 1/2"	28.8	8 x 8	40	43.5	172.5	70	95	45.9 x 1/8Acme
1 1/2"	34.8	8 x 8	44.5	43.5	172.5	70	98	50.6 x 1/8Acme
2"	47.5	10 x 10	52.5	47.5	172.5	76	102	64.1 x 1/8Acme
2 1/2"	60.2	10 x 10	59	47.5	172.5	80	112.5	77.6 x 1/8Acme
3"	72.9	10 x 10	65.5	47.5	172.5	84	114.5	91.1 x 1/8Acme
4"	97.4	11 x 11	79	50	172.5	104	128.5	119.2 x 1/8Acme

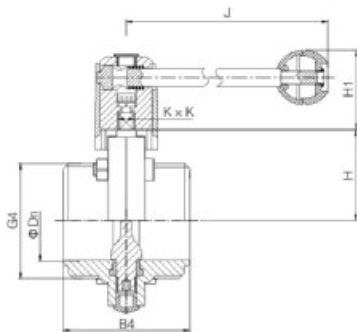

拉式手柄蝶阀
Manual butterfly valve with pull handle
NO.ISO/IDF-VDF130S1

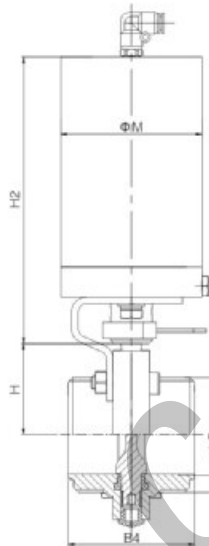

不锈钢气动蝶阀
SS Pneumatic butterfly valve
NO.ISO/IDF-VDF130Q1

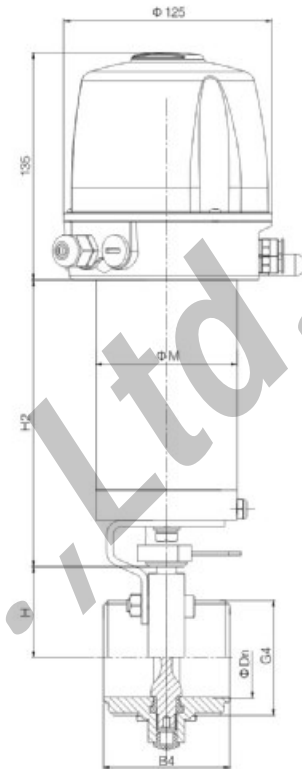

带智能头气动蝶阀
Pneumatic butterfly valve+C-TOP
NO.ISO/IDF-VDF131Q1

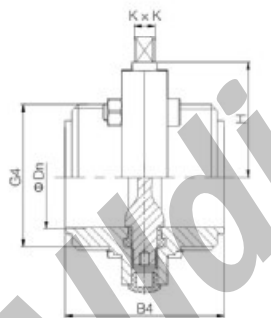

螺纹式MALE/MALE(ISO/IDF)
NO.ISO/IDF-VDF130XX

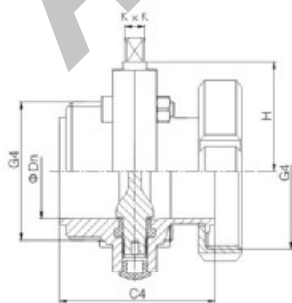

单螺纹单螺母式MALE/NUT(ISO/IDF)
NO.ISO/IDF-VDF1Z0XX-23

蝶阀(ISO/IDF) Butterfly valve (ISO/IDF)

SIZE	Dn	K x K	H	H1	H2	B4	C4	螺纹Male(ISO/IDF)
								G4
1"	22.4	8 x 8	40	43.5	172.5	66	82.5	37.1 x 1/8Acme
1 1/2"	35.1	8 x 8	44.5	43.5	172.5	76	84.5	50.6 x 1/8Acme
2"	47.8	10 x 10	52.5	47.5	172.5	82	88.5	64.1 x 1/8Acme
2 1/2"	59.5	10 x 10	59	47.5	172.5	86	92.5	77.6 x 1/8Acme
3"	72.2	10 x 10	65.5	47.5	172.5	90	94.5	91.1 x 1/8Acme
3.5"	84.9	10 x 10	72	50	172.5	90	96.5	104.7 x 1/6Acme
4"(ISO)	97.6	11 x 11	79	50	172.5	110	109	118.2 x 1/8Acme
4"(IDF)	97.6	11 x 11	79	50	172.5	110	117	125.9 x 1/6Acme

蝶阀尺寸图

Dimension of butterfly valve

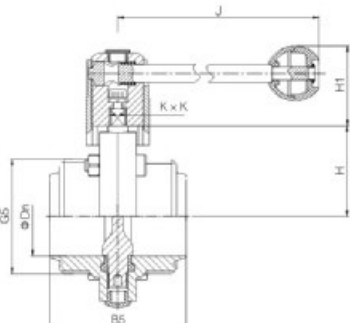

拉式手柄蝶阀
Manual butterfly valve with pull handle
NO.RJT-VDF130S1

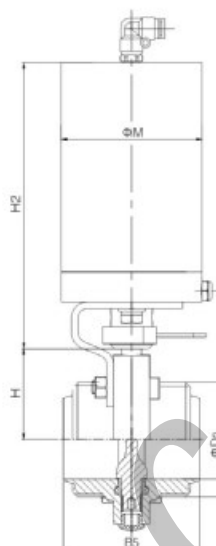

不锈钢气动蝶阀
SS Pneumatic butterfly valve
NO.RJT-VDF130Q1

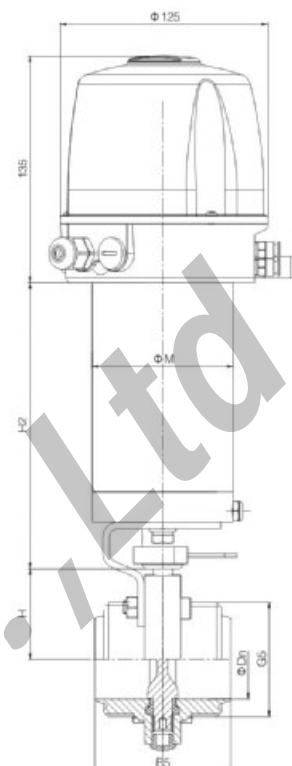

带智能头气动蝶阀
Pneumatic butterfly valve+C-TOP
NO.RJT-VDF131Q1

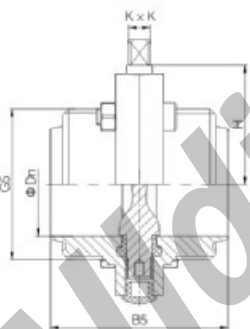

螺纹式MALE/MALE(RJT)
NO.RJT-VDF130XX

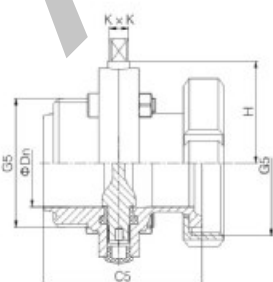

单螺纹单螺母式MALE/NUT(RJT)
NO.RJT-VDF120XX-23

蝶阀(RJT) Butterfly valve (RJT)

SIZE	Dn	K x K	H	H1	H2	B5	C5	螺纹Male(RJT)
								G5
1'	22.2	8 x 8	40	43.5	172.5	80	77.7	45.7 x 1/8TWHIT
1 1/2"	34.9	8 x 8	44.5	43.5	172.5	80	77.7	58.4 x 1/8TWHIT
2"	47.6	10 x 10	52.5	47.5	172.5	84	80.7	72.7 x 1/6TWHIT
2 1/2"	60.3	10 x 10	59	47.5	172.5	84	82.7	85.4 x 1/6TWHIT
3'	73	10 x 10	65.5	47.5	172.5	84	82.7	98.1 x 1/6TWHIT
4'	97.5	11 x 11	79	50	172.5	104	109.4	123.8 x 1/6TWHIT
6"	148	14 x 14	110	52.5	285	150	143.5	174.3 x 1/6TWHIT

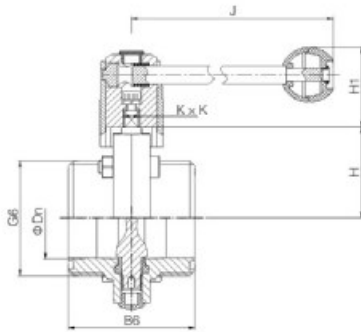

拉式手柄蝶阀
Manual butterfly valve with pull handle
NO.DS-VDF130S1

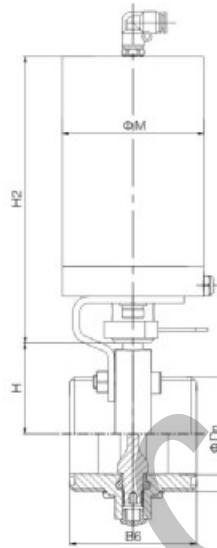

不锈钢气动蝶阀
SS Pneumatic butterfly valve
NO.DS-VDF130Q1

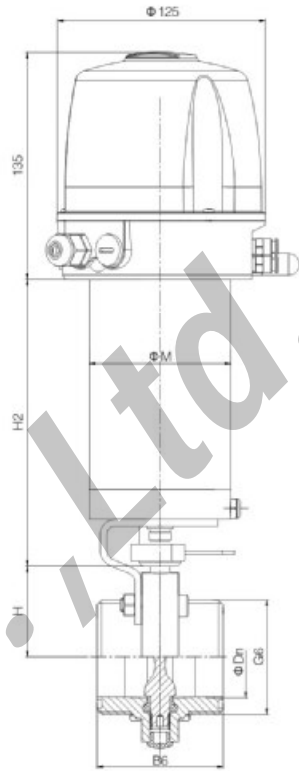

带智能头气动蝶阀
Pneumatic butterfly valve+C-TOP
NO.DS-VDF131Q1

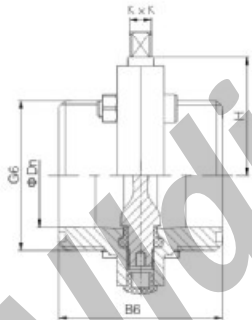

螺纹式MALE/MALE(DS)
NO.DS-VDF130XX

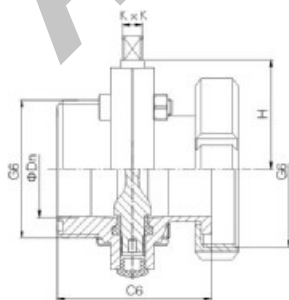

单螺纹单螺母式MALE/NUT(DS)
NO.DS-VDF1Z0XX-23

蝶阀(DS) Butterfly valve(DS)

SIZE	Dn	K x K	H	H1	H2	B6	C6	螺纹Male(DS)
								G6
1"	22.4	8 x 8	40	43.5	172.5	66	74	Rd44 x 1/6
1 1/2"	28.8	8 x 8	40	43.5	172.5	66	74	Rd52 x 1/6
1 1/2"	35.1	8 x 8	44.5	43.5	172.5	70	78	Rd58 x 1/6
2"	47.8	10 x 10	52.5	47.5	172.5	76	84	Rd72 x 1/6
2 1/2"	59.5	10 x 10	59	47.5	172.5	80	90	Rd88 x 1/6
3"	72.2	10 x 10	65.5	47.5	172.5	84	94	Rd100 x 1/6
4"	97.6	11 x 11	79	50	172.5	104	114	Rd130 x 1/4

蝶阀尺寸图

Dimension of butterfly valve

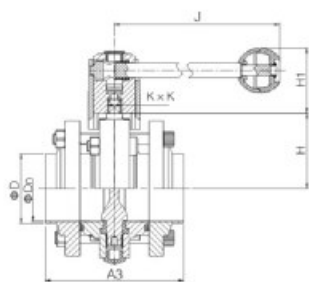

三片式
Three-piece butterfly valve
NO.VDF200S1

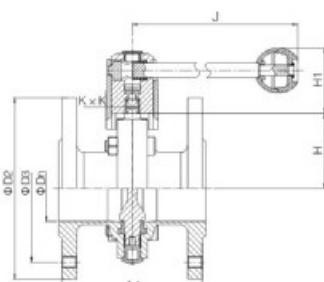

法兰式(圆形)
Flange butterfly valve(Round type)
NO.VDF240S1

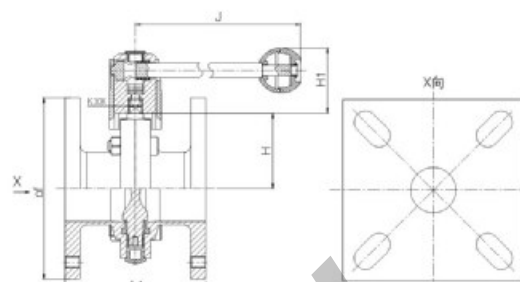

法兰式(四方法兰)
Flange butterfly valve(Square type)
NO.VDF270S1

蝶阀 Butterfly valve (DIN)

SIZE	Dn	D	D2	D3	K × K	J	H	H1	A3	A4	of
DN10	10	13	-	-	8 × 8	126	40	43.5	100	-	-
DN15	15	18/19	95	65	8 × 8	126	40	43.5	100	110	100 × 100
DN20	19	22/23	105	75	8 × 8	126	40	43.5	100	110	100 × 100
DN25	25	28/29	115	85	8 × 8	126	40	43.5	100	110	100 × 100
DN32	31	34/35	135	100	8 × 8	126	44.5	43.5	100	116	100 × 100
DN40	37	40/41	145	110	8 × 8	126	46.5	43.5	100	118	100 × 100
DN50	49	52/53	160	125	10 × 10	133	54.5	47.5	104	120	100 × 100
DN65	66	70	180	145	10 × 10	144	64	47.5	112	124	120 × 120
DN80	81	85	195	160	11 × 11	160	70.5	50	120	130	140 × 140
DN100	100	104	215	180	11 × 11	160	81	50	128	152	140 × 140
DN125	125	129	245	210	14 × 14	257	94.5	52.5	160	178	-
DN150	150	154	280	240	14 × 14	257	110	52.5	180	198	-
DN200	200	204	335	295	14 × 14	397	145	52.5	180	270	-

蝶阀 Butterfly valve (INCH)

SIZE	Dn	D	D2	D3	K × K	J	H	H1	A3	A4	of
1/2"	9.7	12.7	-	-	8 × 8	126	40	43.5	100	-	-
3/4"	15.8	19.1	95	65	8 × 8	126	40	43.5	100	-	100 × 100
1"	22.4	25.4	105	75	8 × 8	126	40	43.5	100	110	100 × 100
1 1/4"	28.8	31.8	115	85	8 × 8	126	40	43.5	100	110	100 × 100
1 1/2"	35.1	38.1	135	100	8 × 8	126	44.5	43.5	100	116	100 × 100
Φ45	41	45	145	110	8 × 8	126	46.5	43.5	100	118	100 × 100
Φ48	45	48	145	110	8 × 8	126	48.5	43.5	100	118	100 × 100
2"	47.8	50.8	145	110	10 × 10	133	52.5	47.5	104	118	100 × 100
Φ57	53	57	160	125	10 × 10	144	54	47.5	104	120	100 × 100
2 1/4"	59.5	63.5	160	125	10 × 10	144	59	47.5	112	120	120 × 120
3"	72.2	76.2	180	145	10 × 10	144	65.5	47.5	112	124	140 × 140
3.5"	85	89	195	160	11 × 11	144	72	50	120	130	140 × 140
4"小	97.6	101.6	195	160	11 × 11	144	79	50	128	130	140 × 140
4"大	97.6	101.6	195	160	11 × 11	160	81	50	128	130	140 × 140
108	104	108	215	180	11 × 11	160	82.5	50	128	152	-
114.3	110.3	114.3	215	180	11 × 11	160	82.5	52.5	160	152	-
133	127	133	245	210	14 × 14	257	94.5	52.5	160	178	-
6"	146.8	152.4	280	240	14 × 14	257	110	52.5	180	198	-
159	153	159	280	240	14 × 14	257	110	52.5	180	198	-
8"	197.6	203.2	335	295	14 × 14	397	145	52.5	180	270	-
219	211	219	335	295	14 × 14	397	145	52.5	180	270	-
10"	247.2	254	390	350	14 × 14	397	174	52.5	-	270	-



铝制气动蝶阀
Horizontal actuator butterfly valve
NO.VDF100Q2

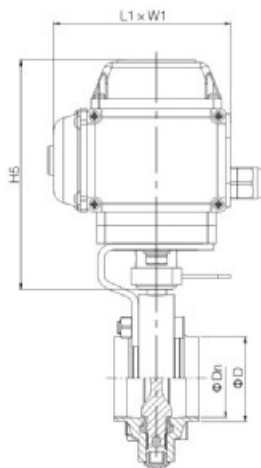

电动蝶阀
Electric actuator butterfly valve
NO.VDF100D1

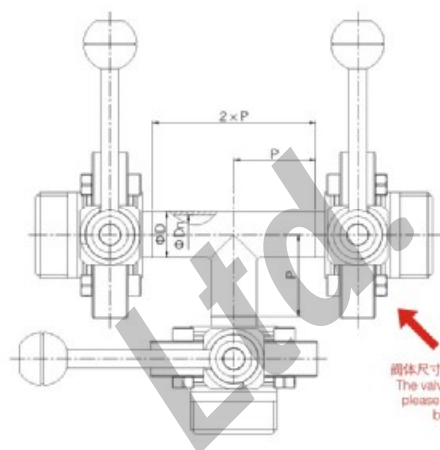

三通蝶阀
Three-way butterfly valve

蝶阀(DIN) Butterfly valve (DIN)

SIZE	Dn	D	H4 双作用	H5	L x W	L1 x W1	P
DN10	10	13	124	167	158x71	165X120	\
DN15	15	18/19	124	167	158x71	165X120	\
DN20	19	22/23	124	167	158x71	165X120	\
DN25	25	28/29	124	167	158x71	165X120	50
DN32	31	34/35	124	167	158x71	165X120	55
DN40	37	40/41	124	167	158x71	165X120	60
DN50	49	52/53	124	167	158x71	165X120	70
DN65	66	70	138	167	190x81	165X120	80
DN80	81	85	138	167	190x81	165X120	90
DN100	100	104	150	167	207x94	165X120	100
DN125	125	129	196	233	213x98.5	212X134	\
DN150	150	154	196	233	213x98.5	212X134	\
DN200	200	204	194	233	213x98.5	212X134	\
DN250	250	254	205	233	259X108.5	212X134	\
DN300	300	304	205	233	259X108.5	212X134	\

蝶阀(INCH) Butterfly valve (INCH)

SIZE	Dn	D	H4 双作用	H5	L x W	L1 x W1
	9.7	12.7	124	167	158x71	165X120
	16.1	19.1	124	167	158x71	165X120
	22.4	25.4	124	167	158x71	165X120
	28.8	31.8	124	167	158x71	165X120
	35.1	38.1	124	167	158x71	165X120
	41	45	124	167	158x71	165X120
	45	48	124	167	158x71	165X120
	47.8	50.8	126	167	158x71	165X120
	53	57	126	167	158x71	165X120
	59.5	63.5	138	167	190x81	165X120
	72.2	76.2	138	167	190x81	165X120
	85	89	138	167	190x81	165X120
	97.6	101.6	150	167	207x94	165X120
	97.6	101.6	150	167	207x94	165X120
	104	108	150	167	207x94	165X120
	110.3	114.3	196	233	213x98.5	165X120
	127	133	196	233	213x98.5	212X134
	146.8	152.4	196	233	213x98.5	212X134
	153	159	196	233	213x98.5	212X134
	197.6	203.2	194	233	213x98.5	212X134
	211	219	194	233	213x98.5	212X134
	247.2	254	205	233	259x108.5	212X134



CHINA DONJOY TECHNOLOGY CO.,LTD.

DONJOY looking forward to your visit! Your telecommunications!



中国·东正
科技有限公司

地址: 温州龙湾区空港新区港富路25号
总机: 0577-86990888
传真: 0577-86998000

Add : No.25 Gang fu Road,
kong gang new District,
Longwan Wenzhou,China
Tel: +86-577-86990888
Fax: +86-577-86998000
E-mail: donjoy@cndonjoy.com

www.cndonjoy.com

法律声明:

目录样册版本属东正所有, 如有抄袭东正将追究其法律责任和经济赔偿。
东正众多技术设计, 都具有专利保护, 如有抄袭, 东正必将追究法律责任和经济赔偿。